



# **Enventive® Concept Deflections Tutorial**

Version 5.0

Copyright © 2023 Enventive, Inc. All rights reserved.

---

## Table of Contents

---

<b>Overview</b> .....	<b>1</b>
Prerequisites .....	1
Preparation .....	1
Overview of the model .....	1
<b>Prepare the Leaf_Spring model</b> .....	<b>3</b>
<b>Build the assembly</b> .....	<b>12</b>
Load and constrain the Leaf_Spring instance .....	12
<b>Bonus exercise: Analyze the insertion force for the Lifter</b> .....	<b>25</b>

## Overview

This advanced tutorial demonstrates a method for simulating deflections in Enventive Concept models. This method can be used for parts with constant thicknesses, like stamped metal leaf springs. An alternate method for simulating deflections is shown in the *Polycurves Tutorial*, Lesson 2: Pin in Contact Lab.

It's important to recognize that all models are only approximations of how a physical object will behave. The method shown in this tutorial may not be appropriate for every application. (Concept does not currently support a method for simulating deflections of straight beams, but we hope to support these types of models in the future.) When simulating deflections, you may also want to consider using Finite Element Analysis (FEA) to validate your Concept models or to identify areas where you can improve the accuracy of your models.

## Prerequisites

This tutorial assumes some experience using Concept, so we recommend completing the [Enventive Quick Tour](#) introductory tutorial and the [Polycurves Tutorial](#) (found in the Enventive Concept Help menu or on the [Enventive website](#) under the Resources menu) before using this tutorial.

## Preparation

Prior to running this tutorial, [download the Deflections Tutorial zip file](#) (located on the Enventive website under [Concept Resources](#)), which includes two files: Leaf\_Spring.enb and Lifter.enb. Unzip and save the files to a local directory of your choice, and note their location.

## Overview of the model

The model we'll create in this tutorial represents a leaf spring that is mounted inside a knob to function as a safety mechanism.

The spring is normally engaged in a slot, preventing the knob from rotating. The safety mechanism is disabled by an arm that lifts the spring out of the slot, so that the spring and the knob are free to rotate.

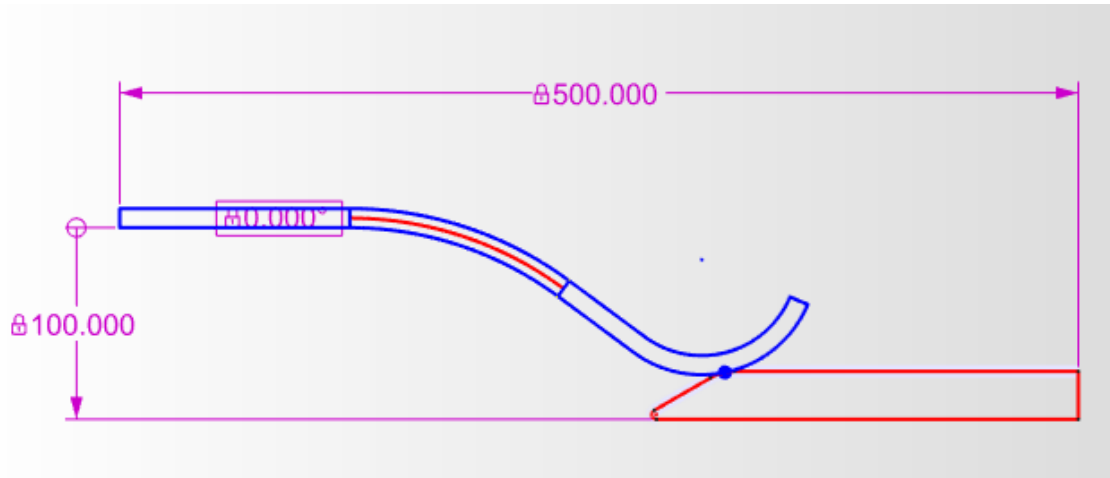

The Leaf\_Spring model represents the free state of the part, and is based on the drawing used for inspecting the parts. In this tutorial, we will simulate how the part deflects. To do this, we will need to add a few features and modify some of the constraints in the area of deflection.

In the next section, we will [prepare the Leaf\\_Spring model](#) for the purpose of simulating deflections.

## Prepare the Leaf\_Spring model

As described in the [tutorial introduction](#), this tutorial demonstrates a method for simulating deflections for parts with constant thicknesses. You can also simulate deflections using the method presented in the Pin in Contact lesson in the [Enventive Concept Polycurves Tutorial](#).

The following steps for preparing the model apply to both deflection simulation methods.

1. Open the copy of the "Leaf\_Spring.enb" file you downloaded and saved, as instructed in [Preparation](#).

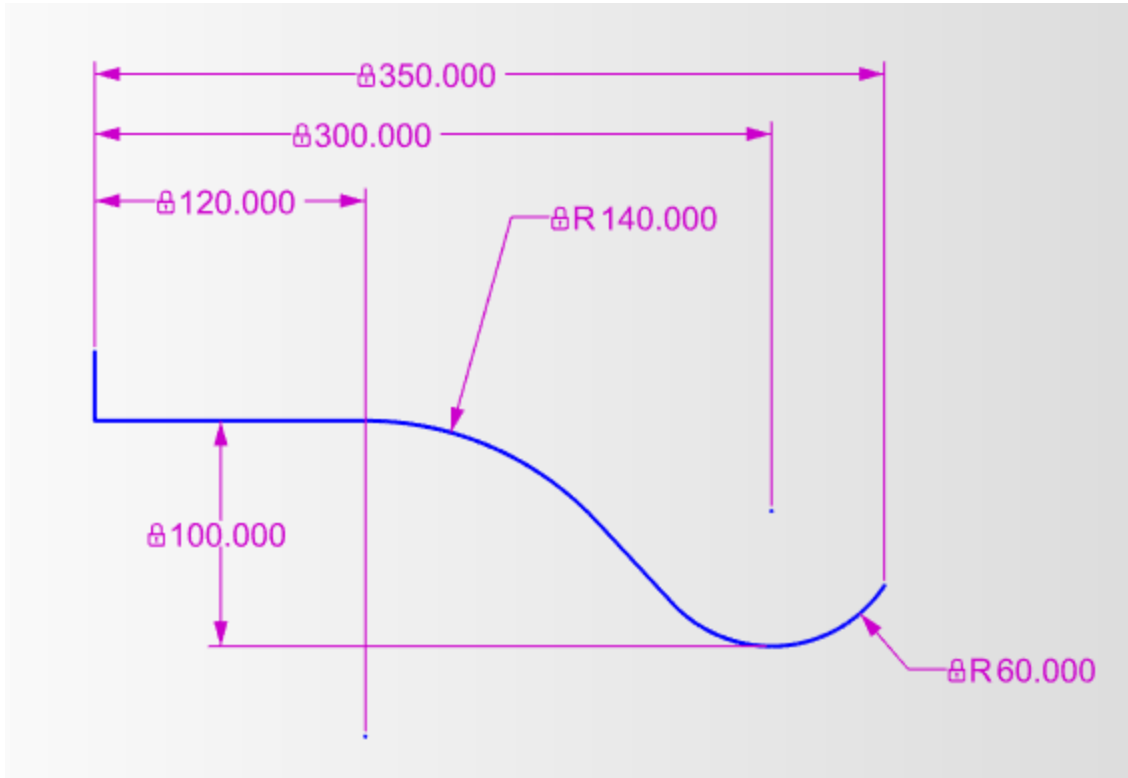

2. Use the Constant Thickness Dimension tool  to select the lines and arcs that represent the bottom surface of the Leaf Spring, and then press **Enter**. Position the ghosted geometry a small distance above the existing geometry, and click to place the new geometry.

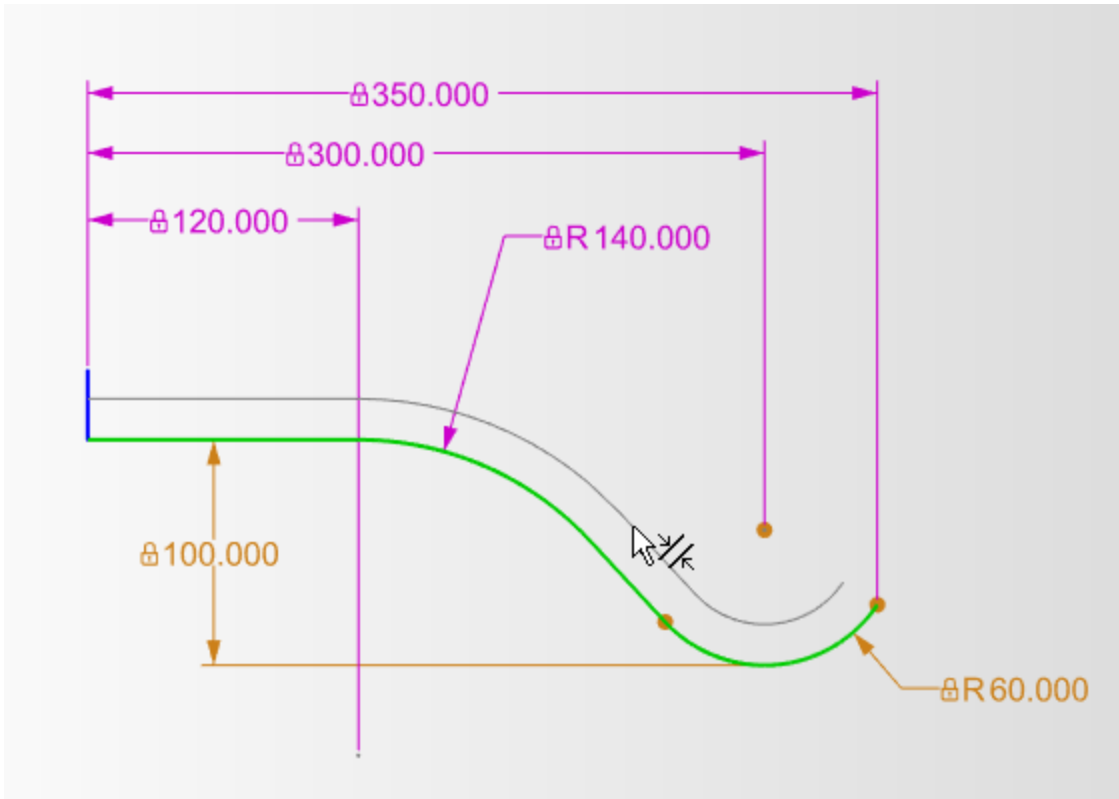

3. Change the value of the constant thickness dimension to 10.0.

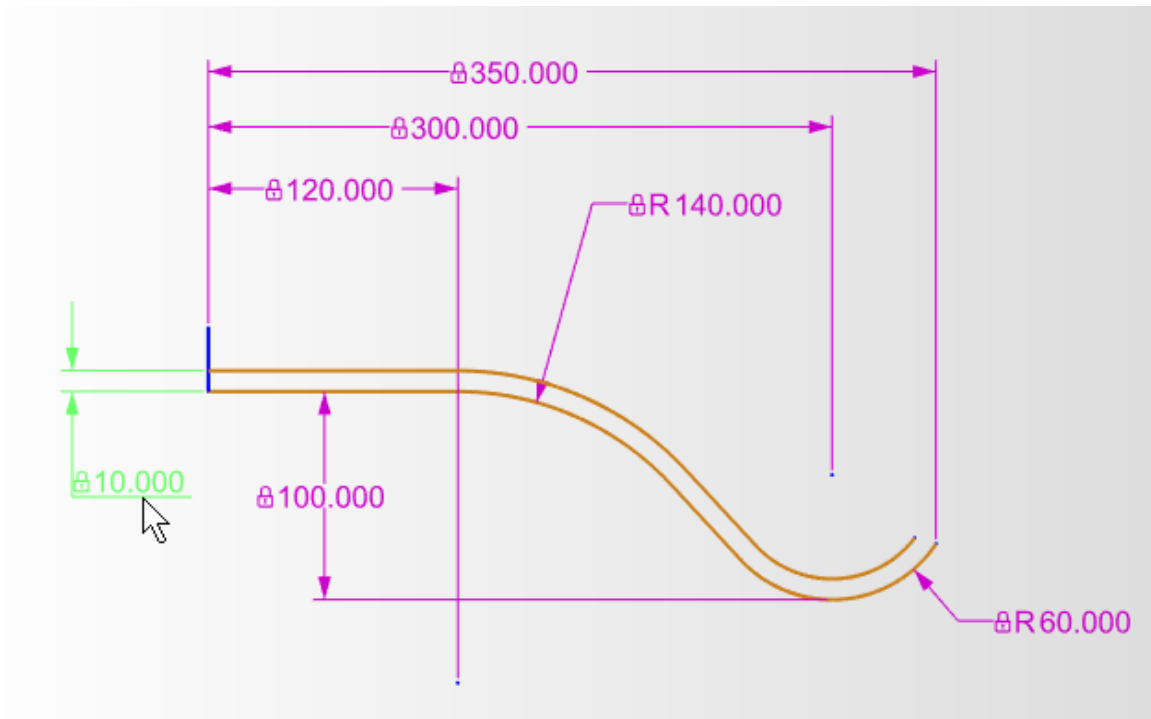

4. On the left side of the Leaf Spring, apply a Coincident point constraint between the endpoint of the new geometry and the top endpoint of the vertical line.

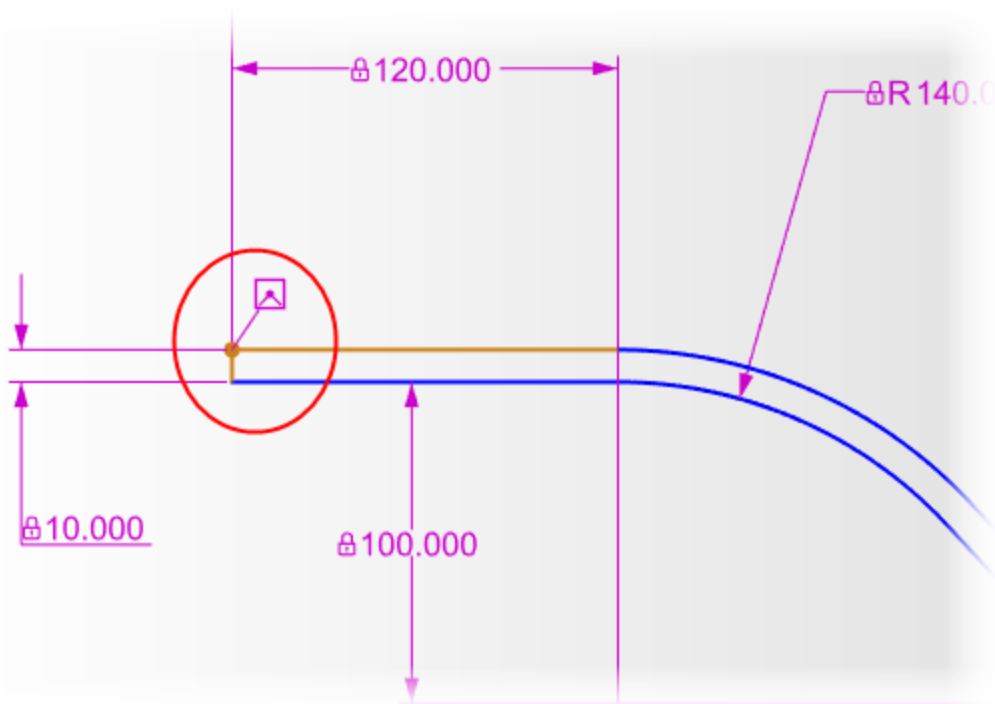

5. On the right side of the Leaf Spring, draw a line connecting the endpoints of the top and bottom geometry, and apply a perpendicularity constraint between the new line and the bottom arc.

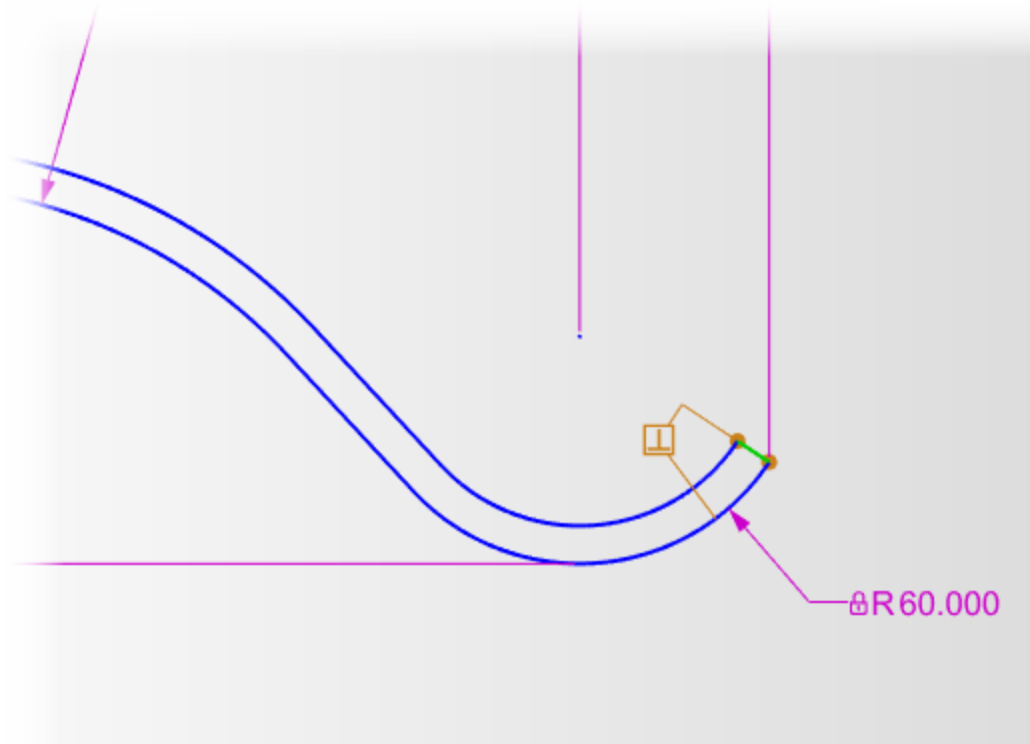

6. Select the 10.0 constant thickness dimension, and note that the Perturb area in the Properties Explorer shows two "Element" options: "All," which perturbs all elements, and an option that lets you select individual elements (1 to 7) to perturb.
7. Set the step size to 0.5, and use the slider bar to observe how the top surface of the Leaf Spring moves when perturbing "All" compared to perturbing the individual elements.

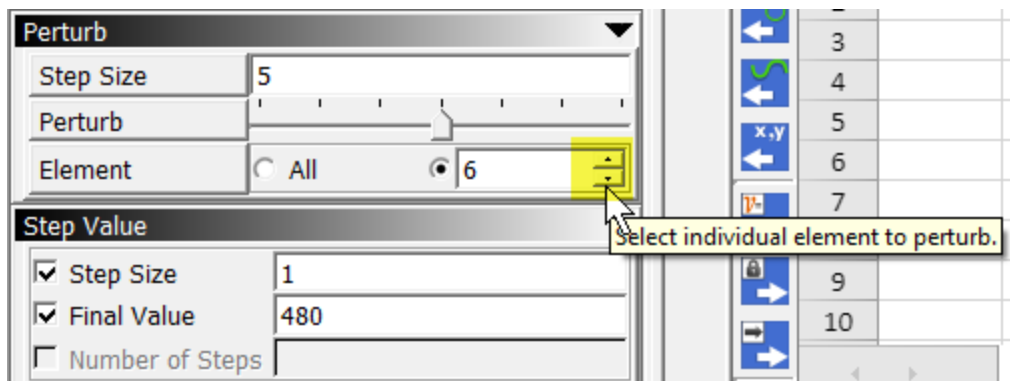
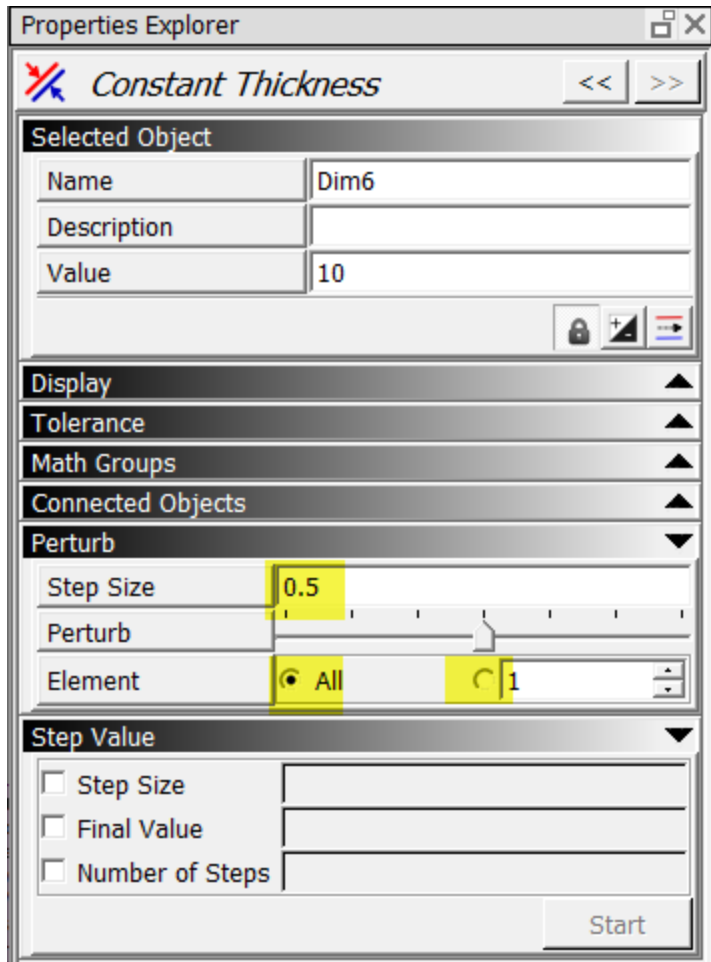

The illustration below indicates the location of the seven elements for the constant thickness dimension, at the endpoints of lines/arcs and the mid-spans of arcs. (**Note:** For more information about perturbing constant thickness dimensions, see [Enventive Online Help](#).)

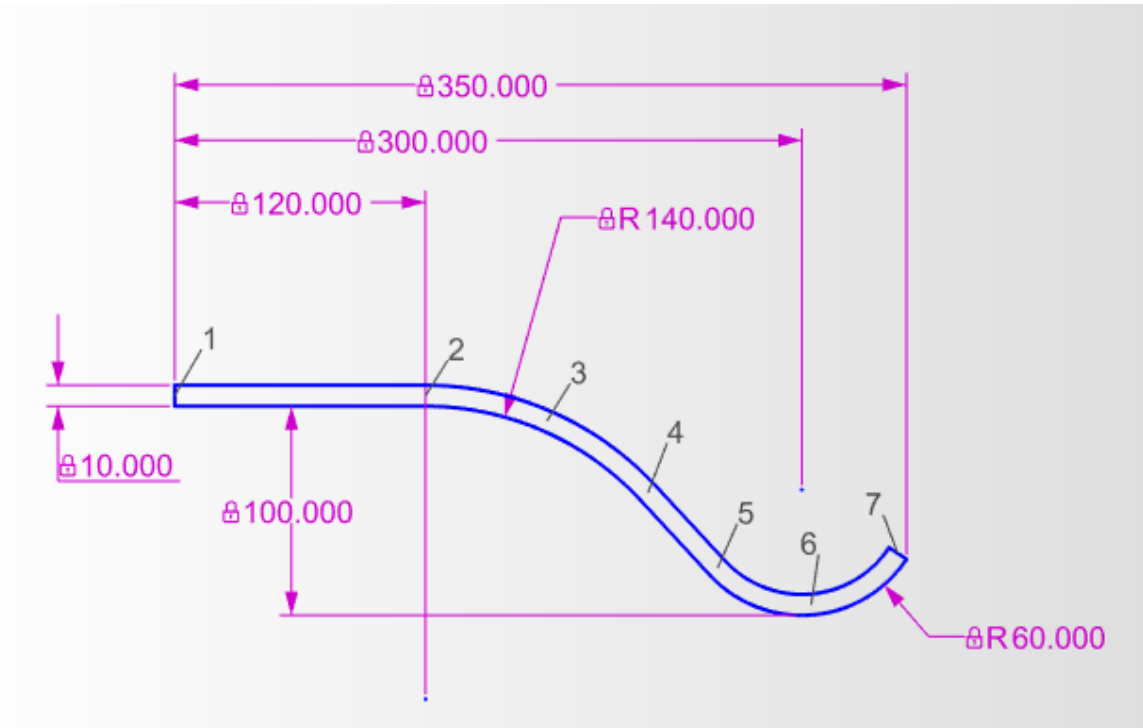

8. Add two line segments at the tangency points of the large radius, as shown below.

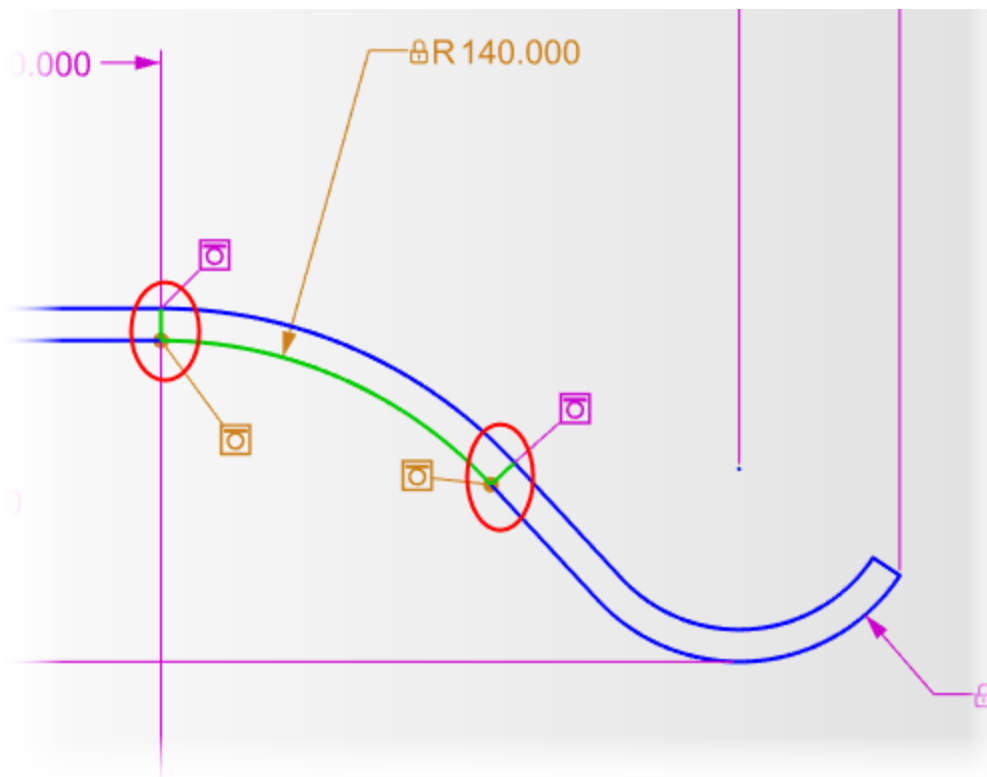

9. Create an arc between the two new line segments. When creating the arc, click directly on the line segments to automatically create Point On Object constraints between the arc and the line segments.

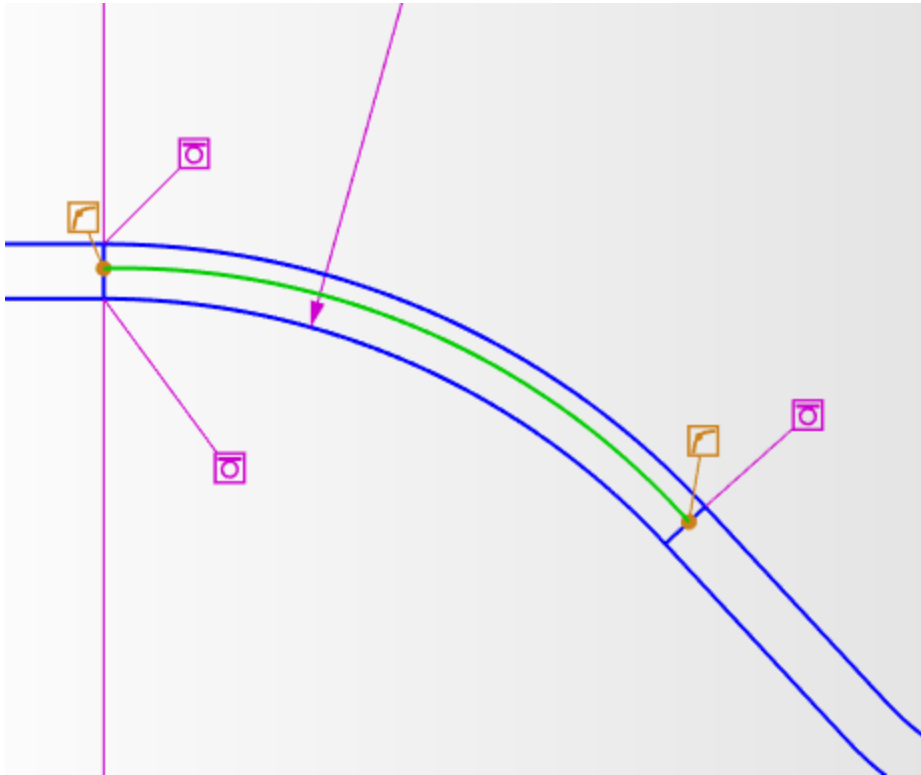

10. Delete one of the Point On Object constraints you created in the previous step, and replace it with a Point At Midpoint constraint.

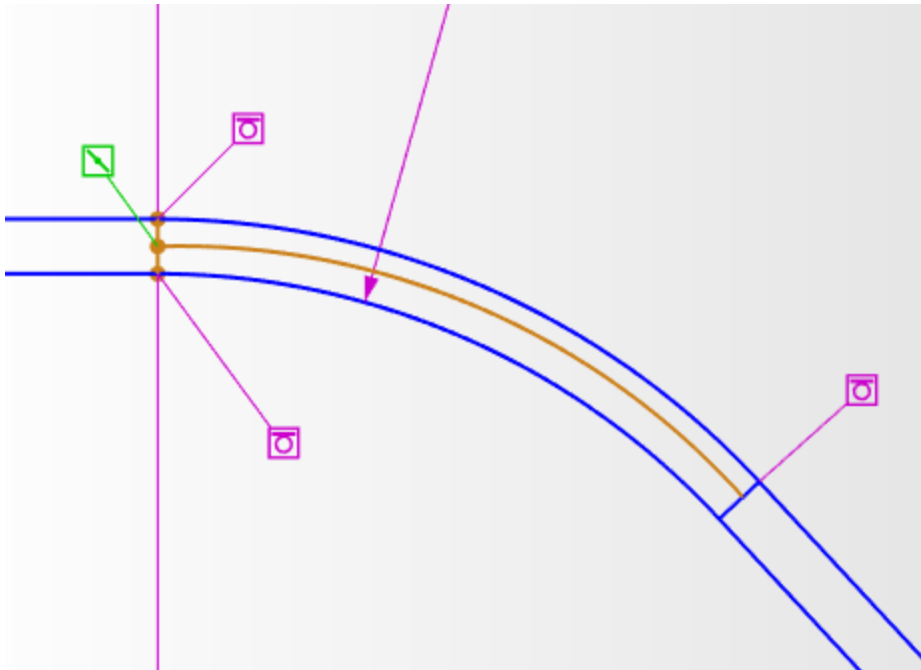

11. Constrain the centerline arc to be concentric with the inner radius.

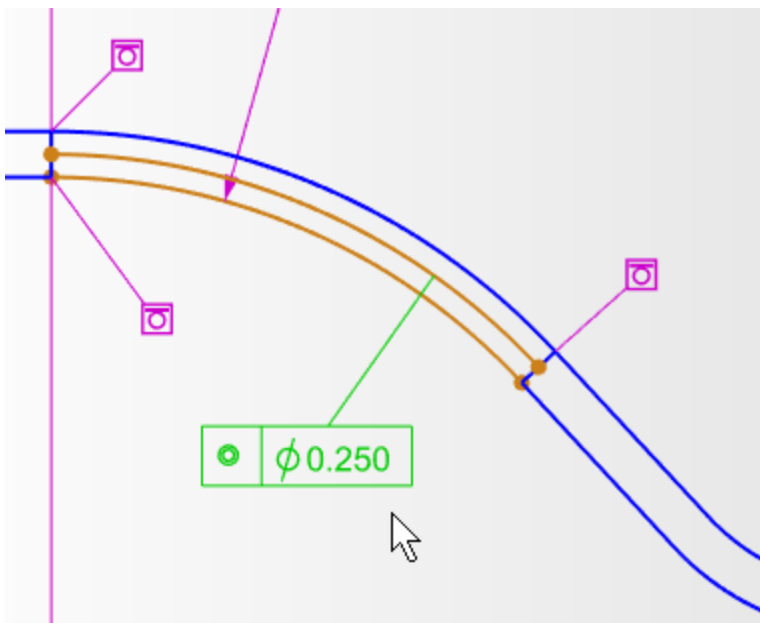

12. Change the tolerance value of the Concentric constraint to 0.0.

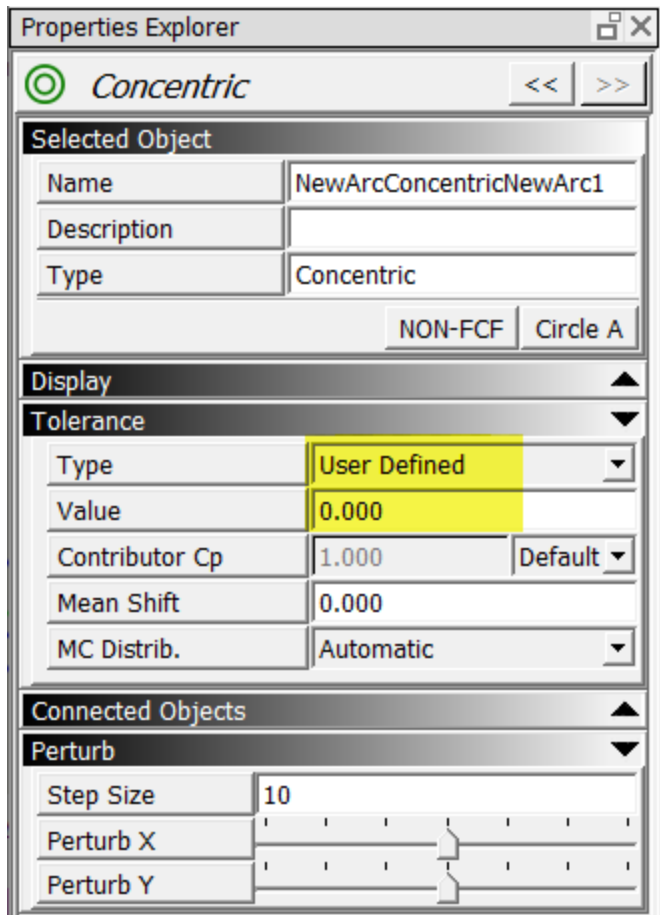

13. Save the "Leaf\_Spring" model file.

Next, we will [build the assembly](#).

## Build the assembly

In this section, we'll build an assembly that simulates deflections using the Leaf\_Spring model you worked with in the previous section, [Preparing the model](#), and the Lifter model you saved as part of [preparation](#).

### Load and constrain the Leaf\_Spring instance

1. Create a new file called "Deflection Assy."
2. Load an instance of the Leaf\_Spring model into Deflection Assy.
3. Apply a Fixed Point constraint to the leftmost horizontal line, which also adds a Line At Angle constraint, as shown below.

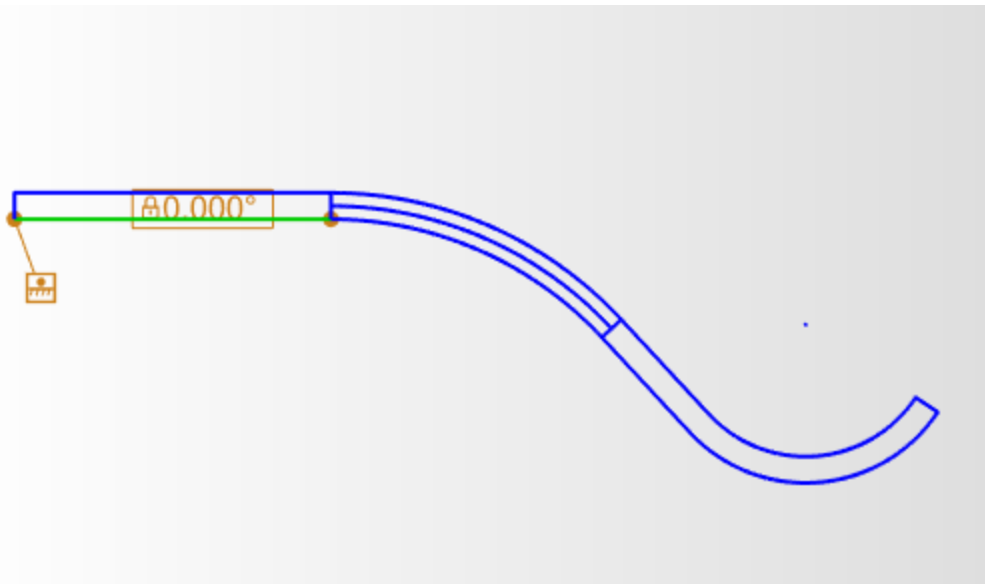

4. Select the curved tip geometry, as highlighted below, and move it to the Hidden layer.

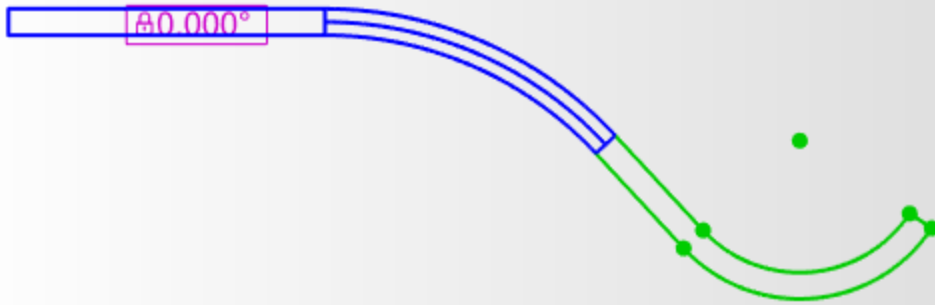

The Leaf Spring should now look like the following illustration.

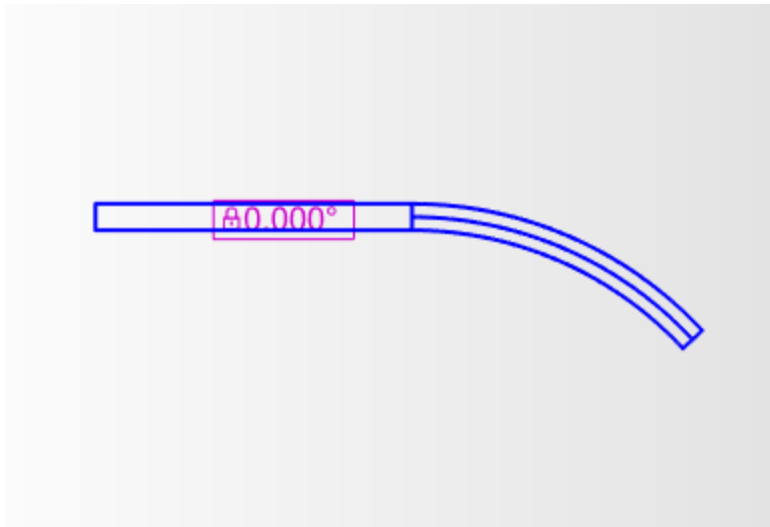

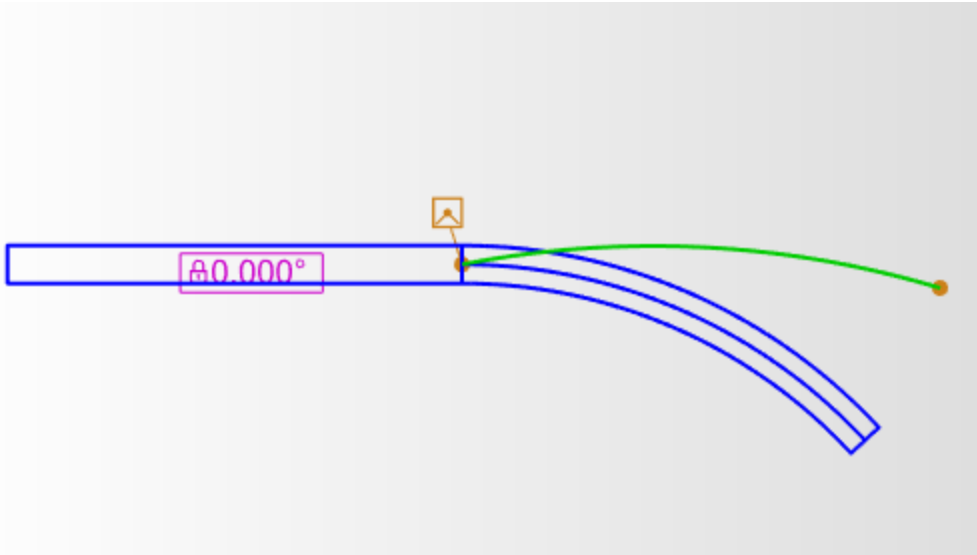

5. Sketch an arc, which will be used to simulate the area of deflection, clicking on the left end of the centerline arc to automatically create a coincident point constraint, as shown below. *Do not* connect the other end of the arc to the centerline arc.

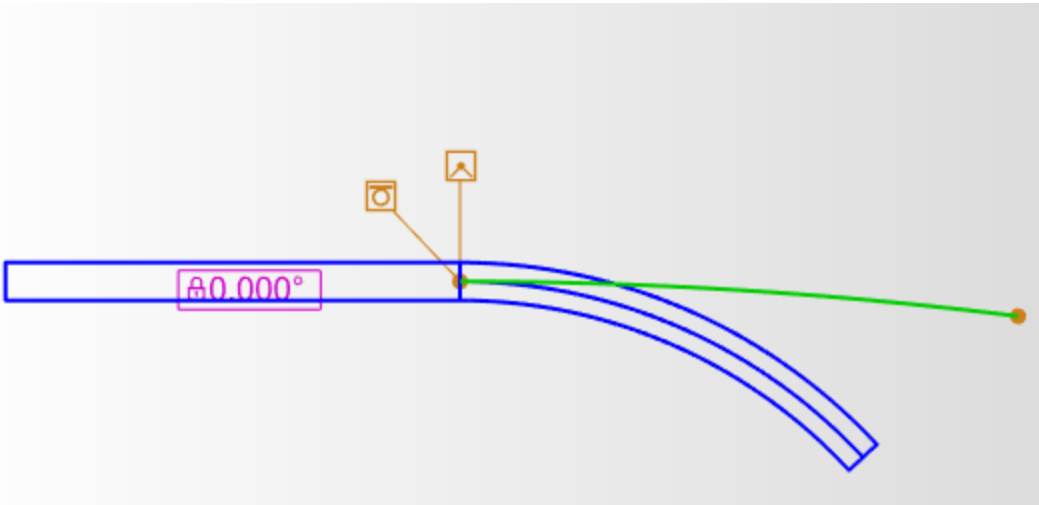

6. In the Properties Explorer's Display area, change the color of the deflection arc to red to differentiate it from the other geometry.
7. Make the deflection arc tangent to the centerline arc.



8. Use the Curve Length Dimension tool  to create arc length dimensions for the centerline arc and then for the new deflection arc. The centerline arc length dimension should be derived, and the deflection arc length dimension should be locked.
9. Unlock the arc length dimension for the deflection arc, and use the Length Equal Constraint tool  to set the two arc length dimensions equal to each other.

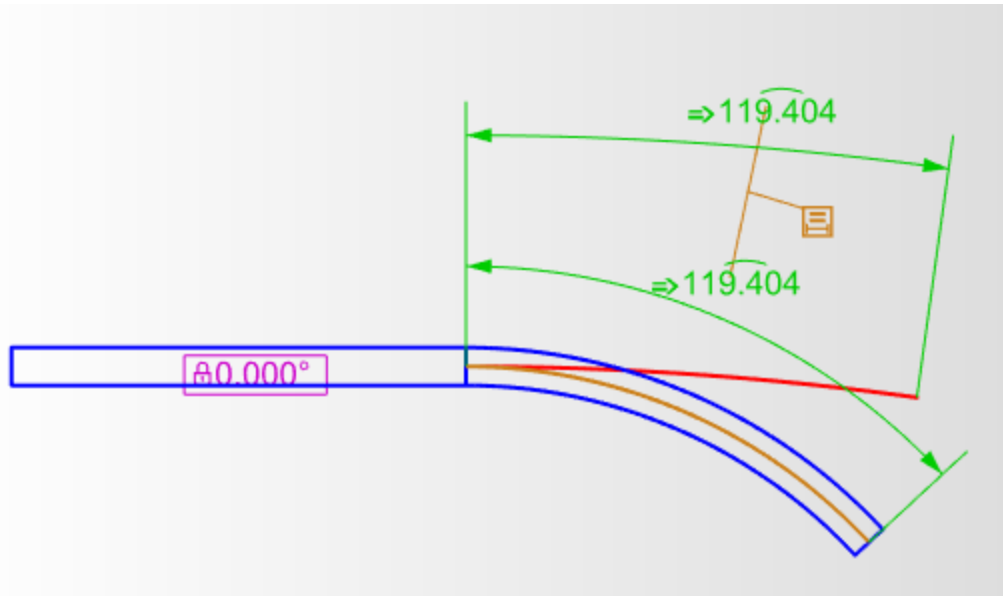

10. Load an instance of the Lifter.enb file (which you downloaded and saved as part of [preparing for this tutorial](#)), placing it to the bottom right of the Leaf Spring, as shown in the illustration below.

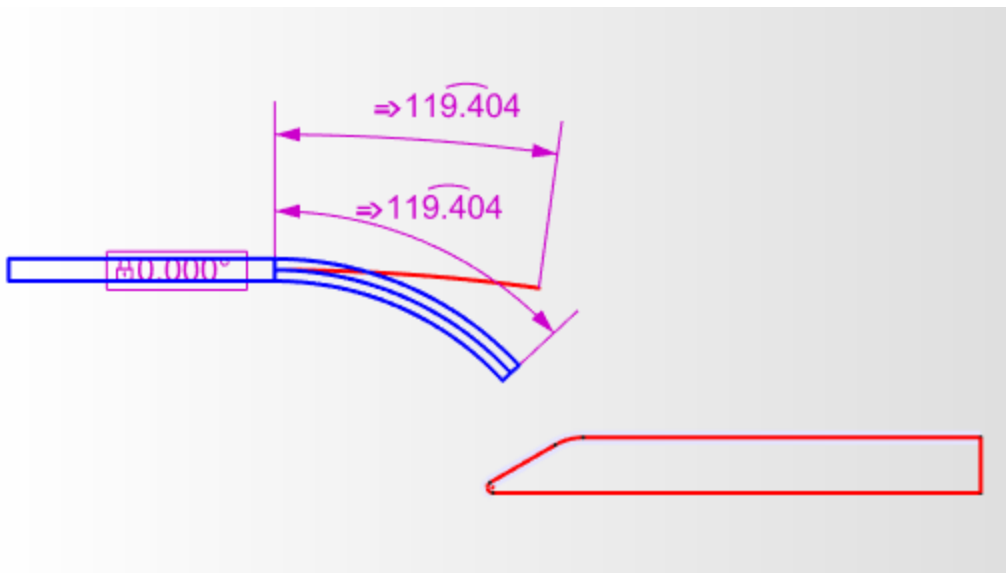

11. Create a line-to-line dimension  between the bottom surface of the Lifter and the bottom surface (left horizontal line) of the Leaf Spring. A parallel constraint is also added between the two surfaces. Set the value of the line-to-line dimension to 100.00.

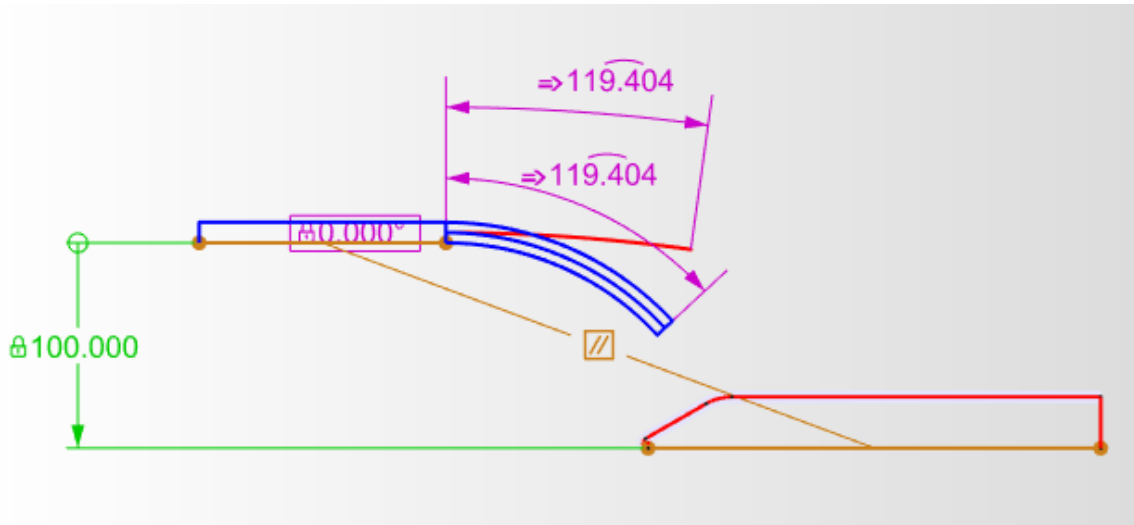

12. Create a point-to-line dimension  between the upper left corner of the straight end of the Leaf Spring and the right vertical edge of the Lifter.

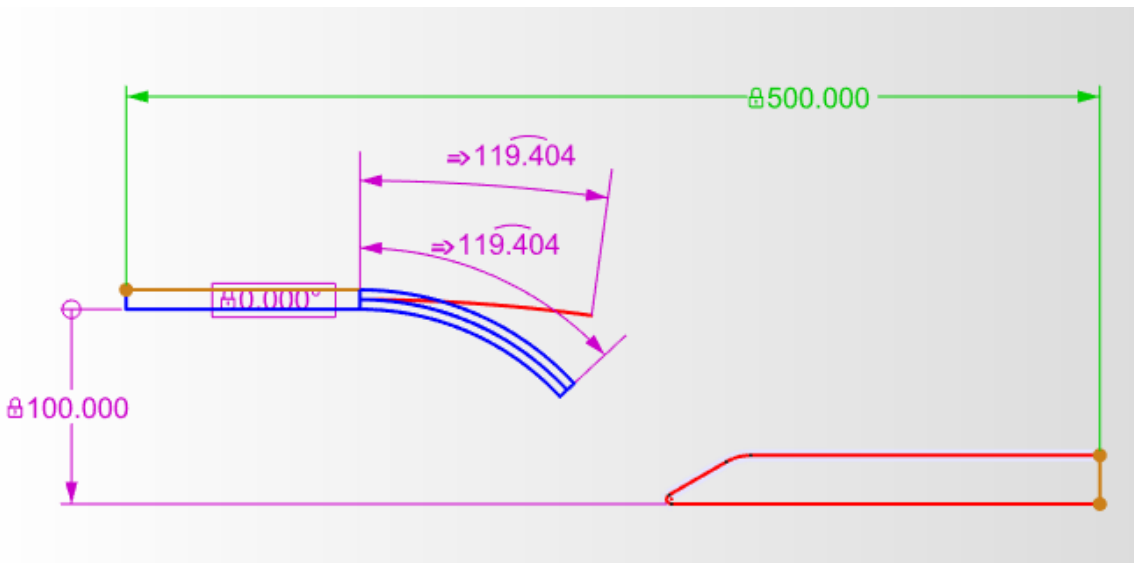

13. Name the point-to-line dimension "EngagementDistance" and set its value to 500.00.

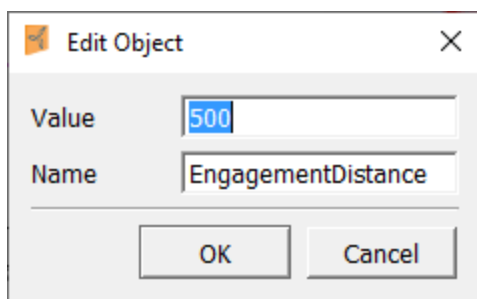

14. Load another instance of the Leaf\_Spring model. Although the instance may appear with a different number appended to it in the Model Explorer, we'll refer to this instance as "Leaf Spring 2." You may change its name in the Model Explorer if you like.

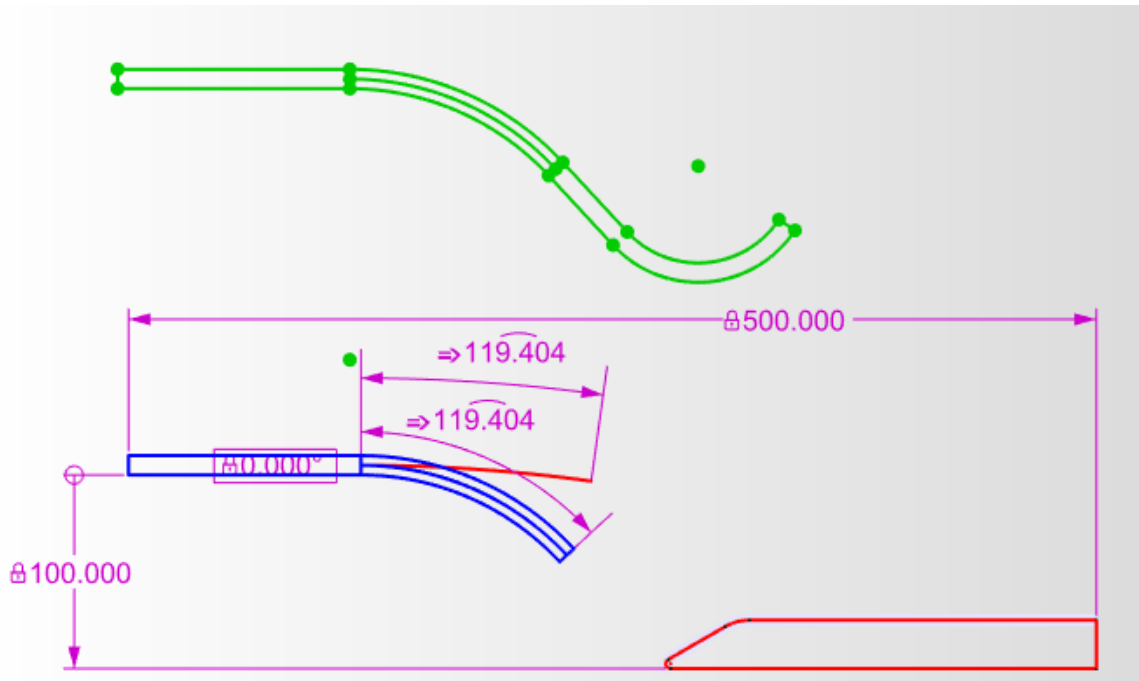

15. Select the flat section of the Leaf Spring 2 instance and move it to the Hidden layer.

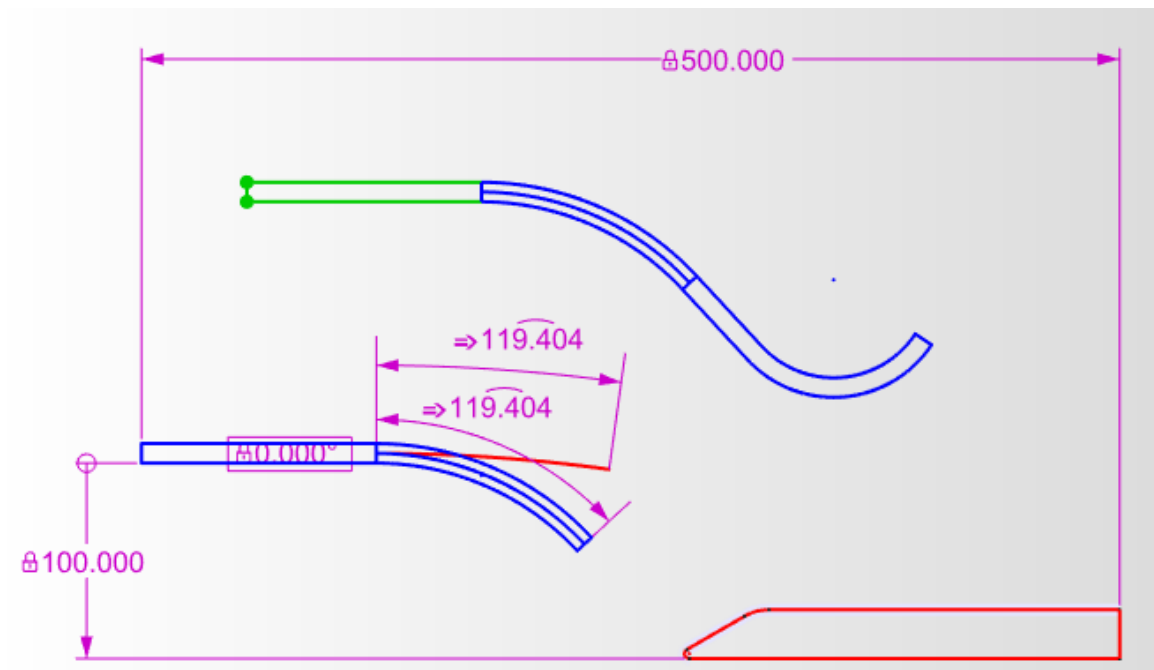

16. Select the portion of the Leaf Spring 2 instance that contains the centerline arc, and change its color to help differentiate between the arcs as we proceed. For our example, we made this geometry yellow.

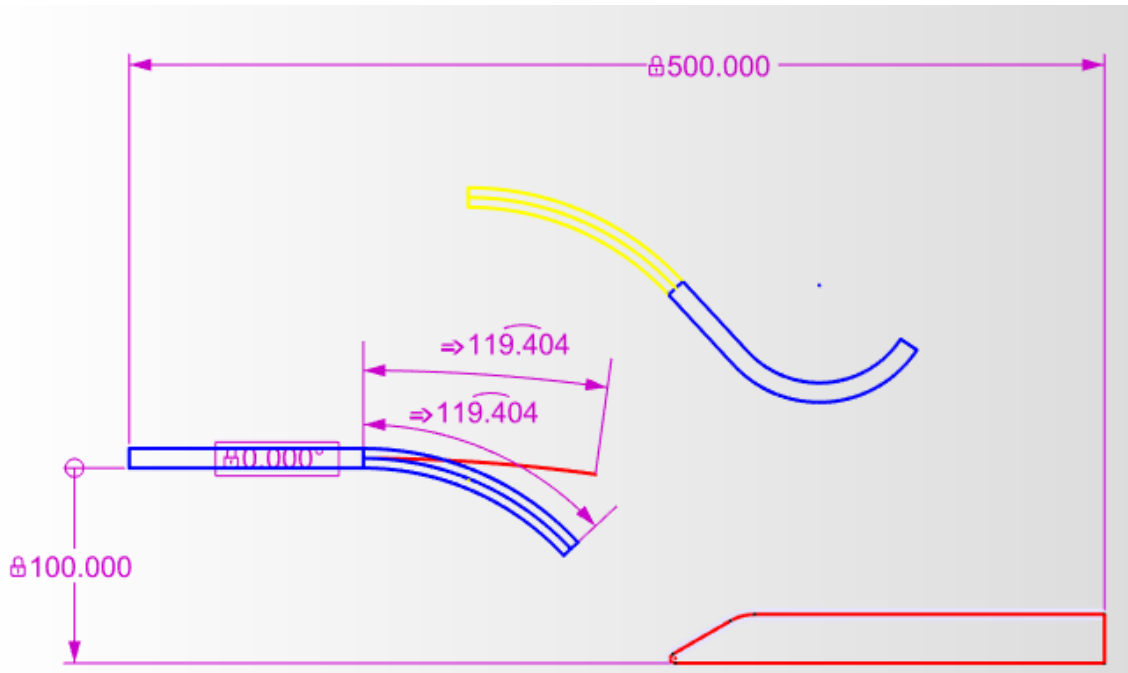

17. Constrain the point at the free end of the (red) deflection arc coincident to the point on the right side of the (yellow) centerline arc of Leaf Spring 2.

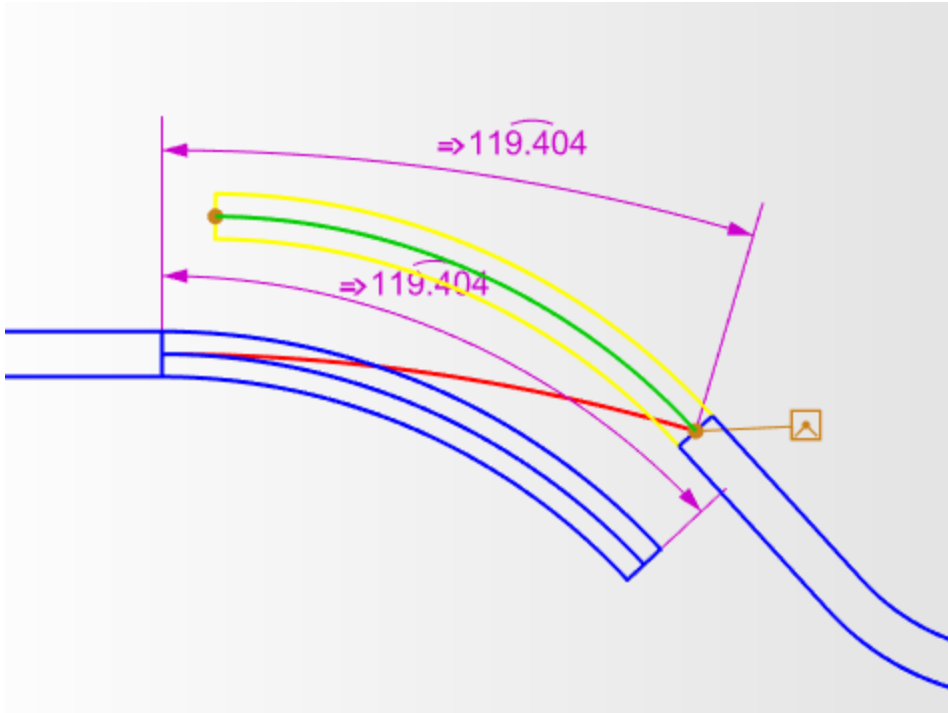

18. Constrain the deflection and centerline arcs to be tangent.

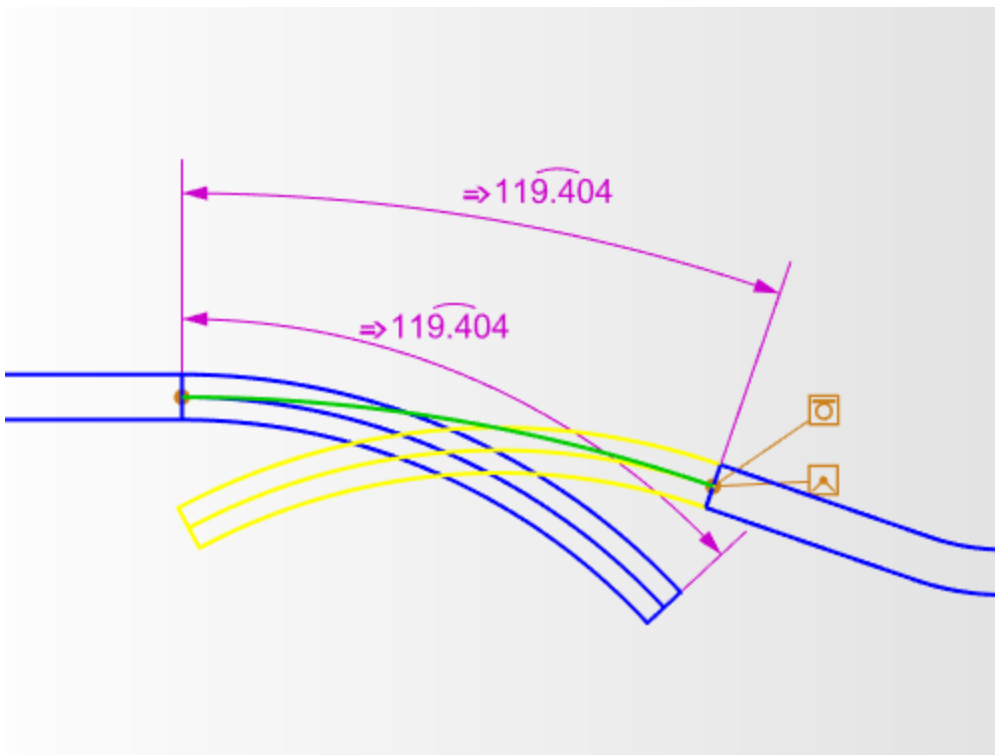

19. Constrain the Leaf Spring 2 tip radius tangent to the polycurve along the top surface of the Lifter, using the shortcut menu to select the polycurve along the small arc on the top of the Lifter.

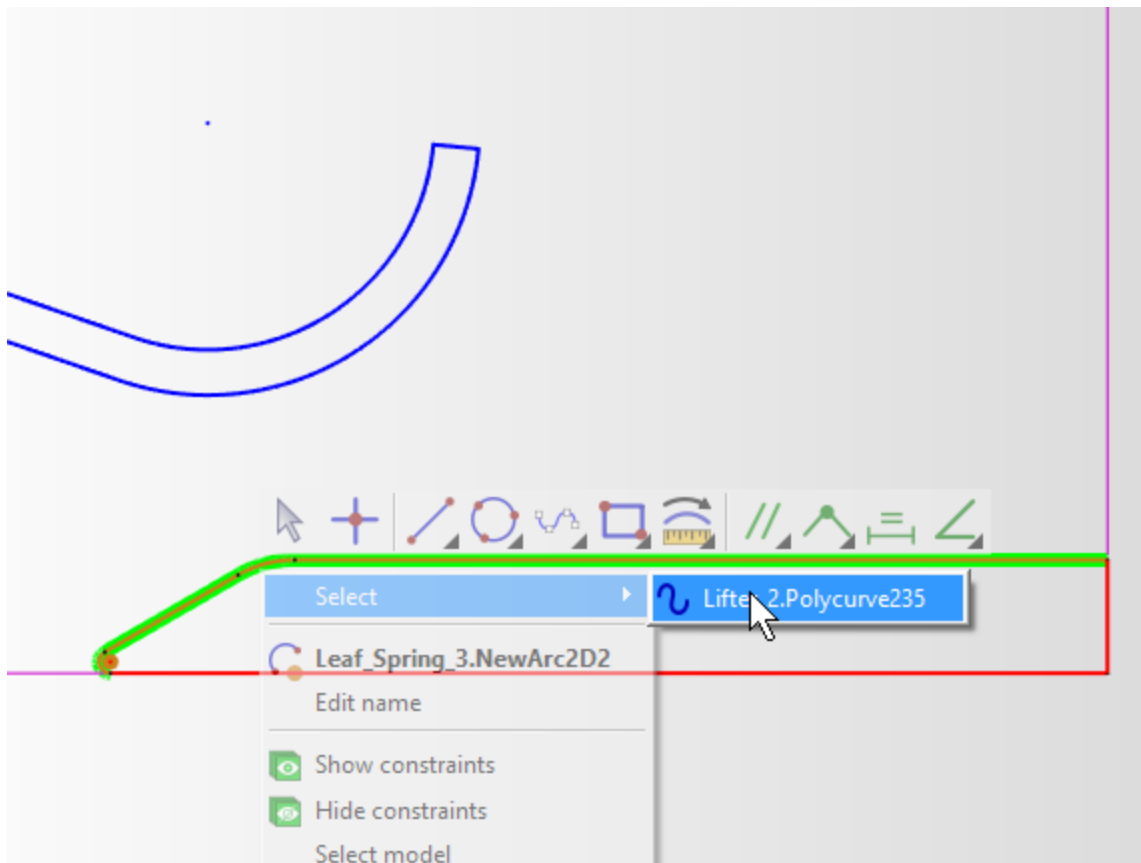

The constraint should appear as shown in the following illustration.

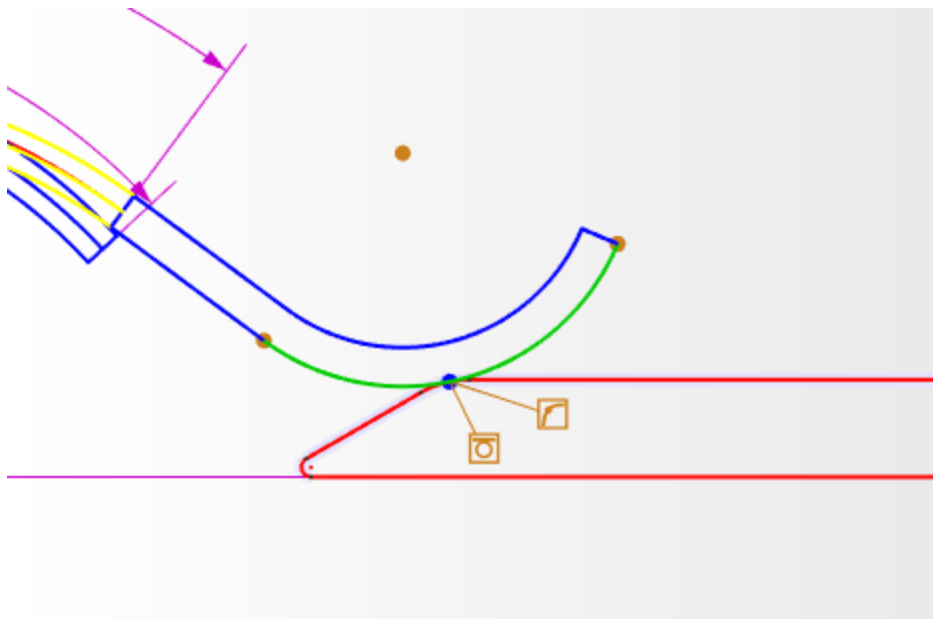

20. Verify that the tangency constraint was created between the tip radius and the polycurve by selecting the tangency constraint and looking at its Connected Objects list in the Properties Explorer.

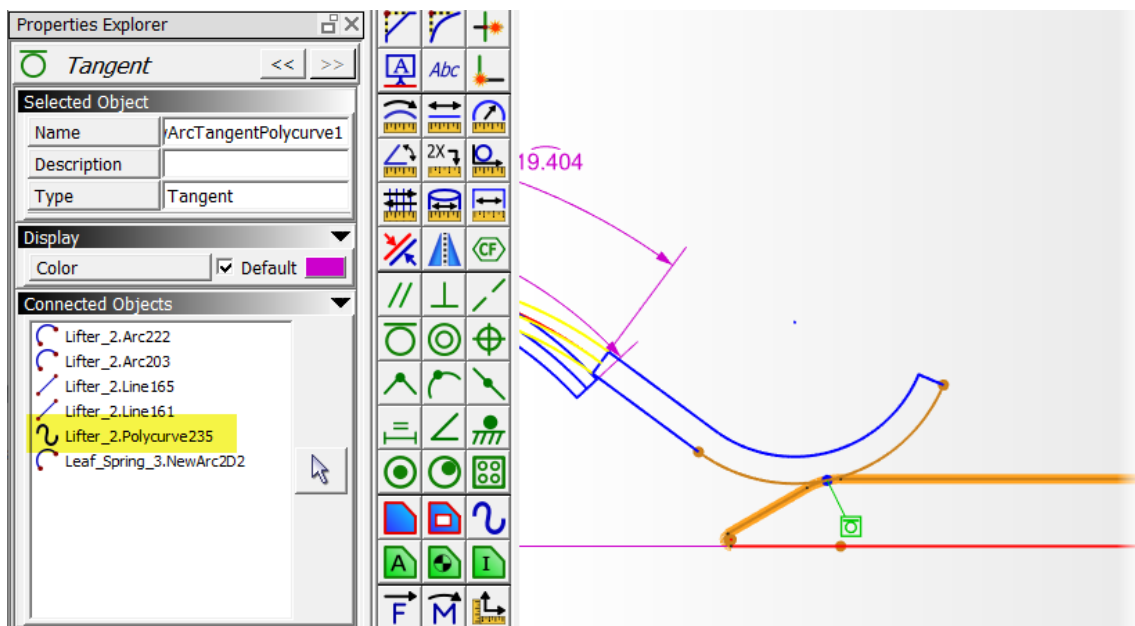

21. To make it easier to visualize the model, move all of the instance geometry in the deflection area to the Hidden layer so that only the deflection arc, the radius tip, and the flat end of the spring remain visible on the Geometry layer. Also move the two arc length dimensions to the Hidden layer. The assembly should appear as shown in the illustration

below.

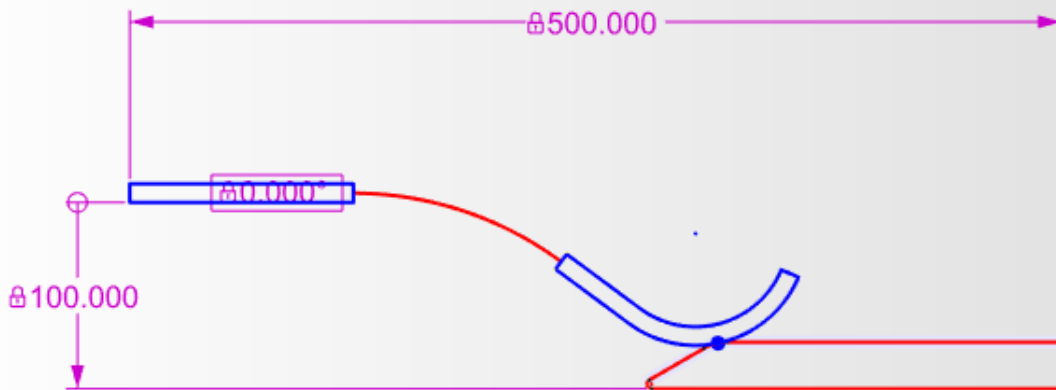

22. Sketch two new arcs and constrain them to be concentric with the deflection arc. (Note: be sure to do this step before applying the constraints described in the next step.)

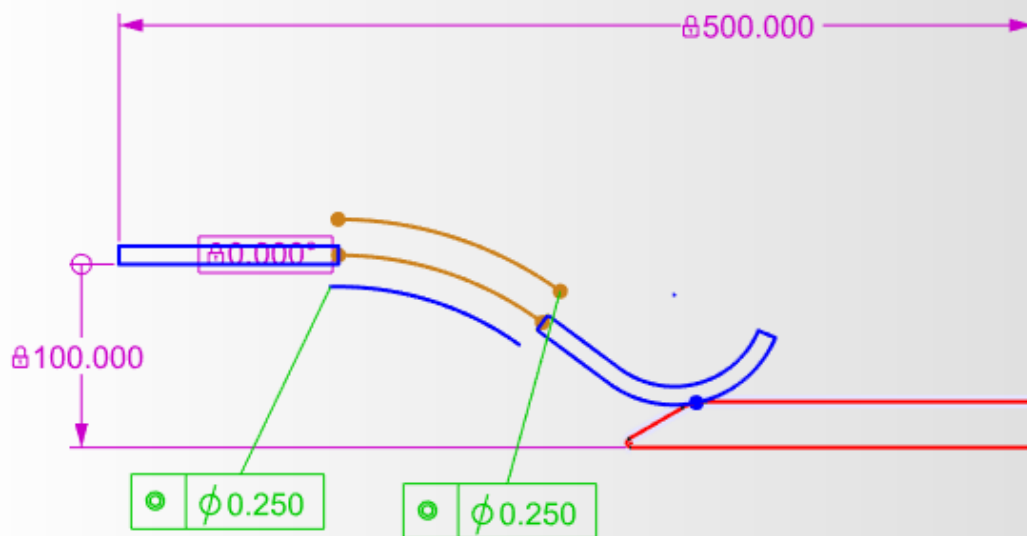

23. Apply Coincident Point and Point On Object constraints to attach the end points of the new arcs to the two Leaf Spring segments, as shown below.

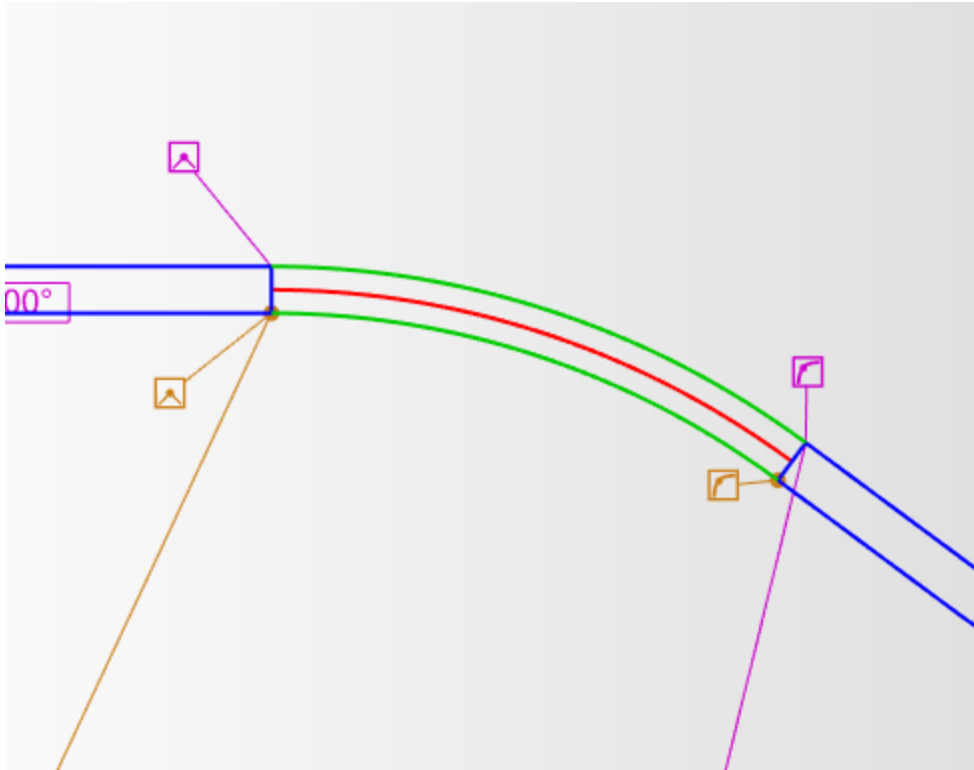

24. Select the Concentric constraints, toggle them to NON-FCF in the Properties Explorer, and move the constraints to the Hidden layer.

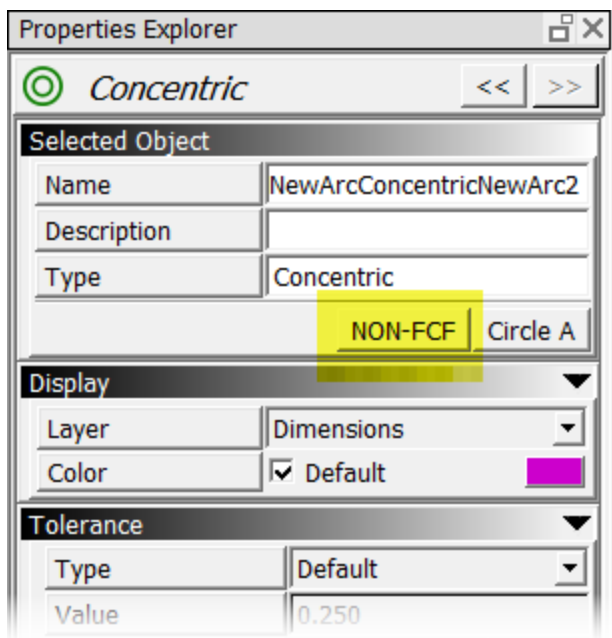

25. Zoom All to see the entire assembly.

26. Select the EngagementDistance dimension that controls the location of the Lifter.
27. In the Properties Explorer, change the perturb Step Size value to 5.
28. Using the Perturb slider or the scroll wheel, perturb the dimension to see how the model represents the deflection of the Leaf Spring.

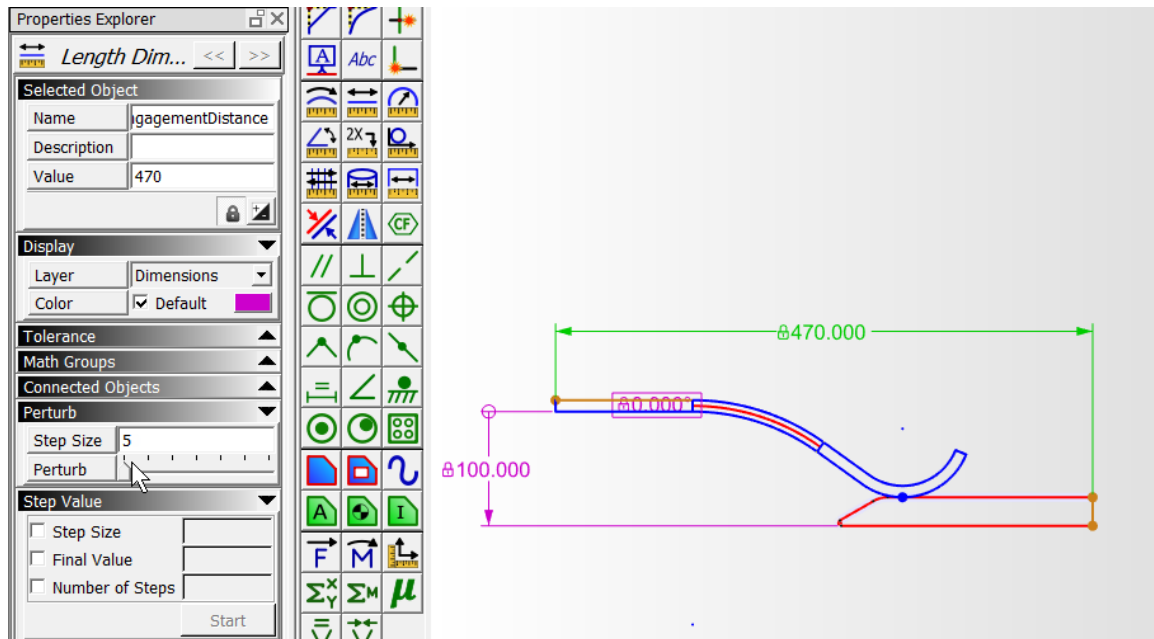

This method allows the model to remain dimensioned and constrained as specified within the individual model drawing, so the drawing dimensions will appear as contributors in tolerance analysis reports.

Congratulations! You have completed the Deflections Tutorial.

For more practice, run the bonus exercise to [analyze the insertion force for the Lifter](#).

## Bonus exercise: Analyze the insertion force for the Lifter

In this section, we'll set up a free-body diagram to analyze the insertion force for the Lifter using the assembly we created in the [previous section](#) of this tutorial.

1. Draw a force  $\vec{F}$  and constrain the arrowhead to be coincident with the tangency point where the Leaf Spring contacts the Lifter.

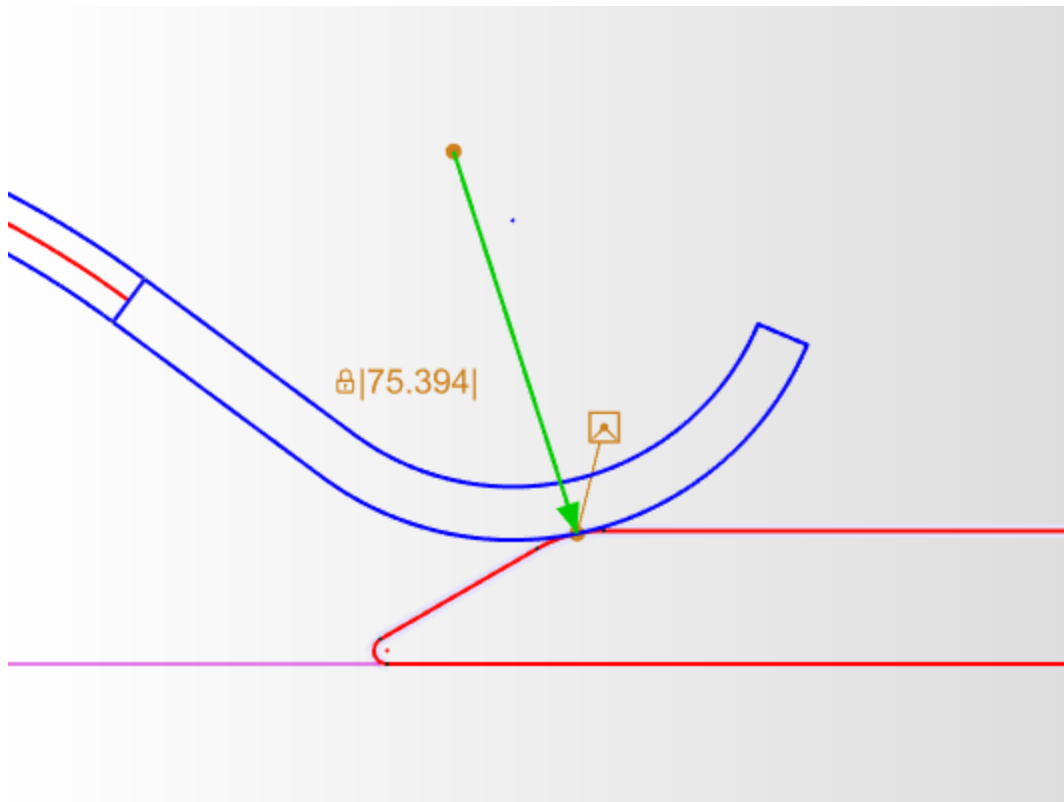

2. Apply a perpendicularity constraint between the force vector and the bottom arc of the Leaf Spring.

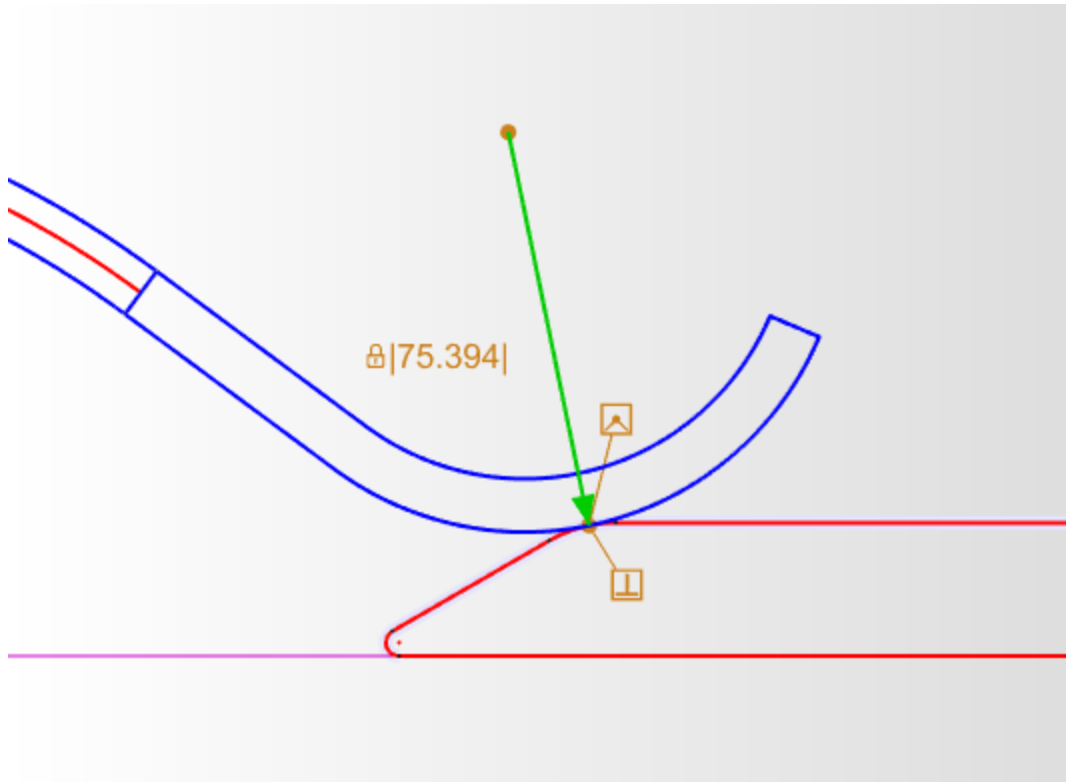

3. Use the Force X, Y Components tool  to display the horizontal and vertical components of the force vector. Change the name of the vertical (YDim) component to "DeflectionForce" in the parameter table.

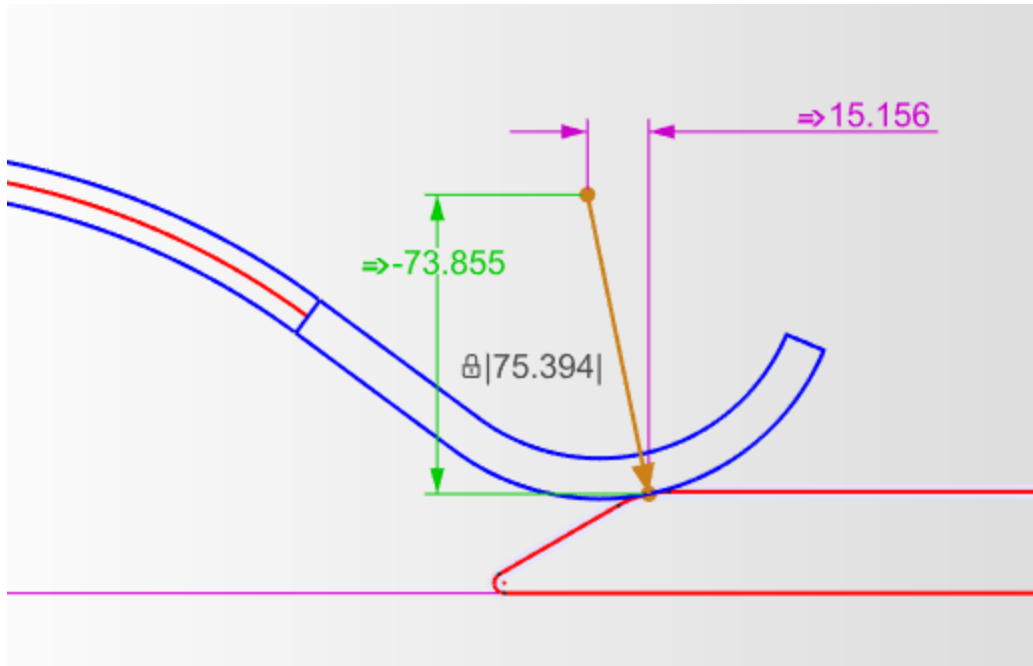

4. Use the Circular Edge Dimension tool  to create a dimension between the bottom arc and the bottom of the flat section of the Leaf Spring. Name this dimension "Height\_Deflected."

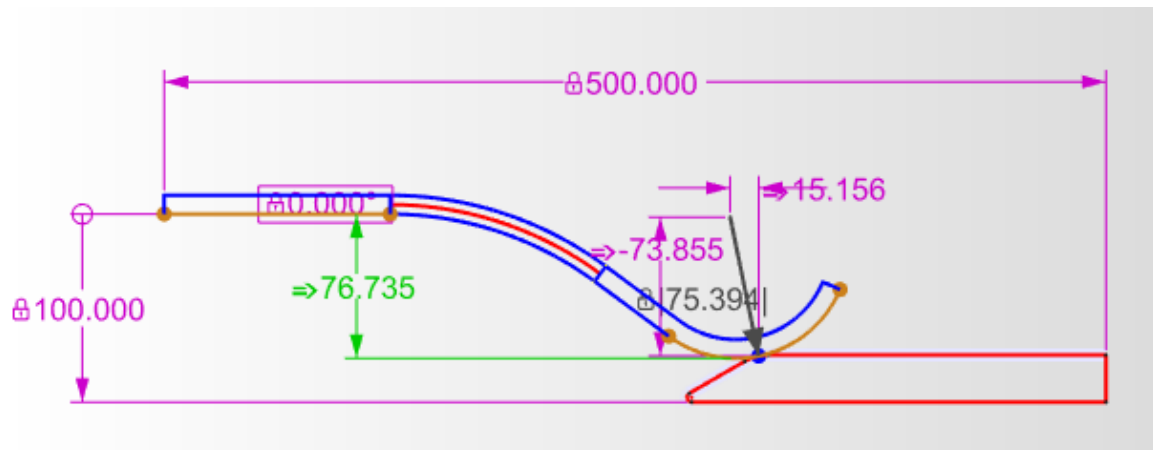

5. Unlock the force vector. This will also unlock the force xy components.

	L	T	Name	Value
1	→		Dim1	119.404409546
2	→		Dim2	119.404409546
3	🔒		Dim3	100
4	🔒		ADim1	0
5	🔒		EngagementDistance	500
6	🔓	F↕	ForValDim2	75.3943265756
7	🔓		ForXDim5	15.1556222639
8	🔓		DeflectionForce	-73.8553423497
9	→		Height_Deflected	76.7350597207

6. Create the following equation:

$$\text{DeflectionForce} = \text{stiffness} * (\text{Height\_Deflected} - \text{Leaf\_Spring.Height\_FreeState})$$

(**Note:** *Leaf\_Spring.Height\_FreeState* is a dimension that exists inside the *Leaf\_Spring* model.)

7. Enter a value of 3.0 for the stiffness variable in the parameter table. Now the reaction force value should be derived, and the direction and magnitude of the force will change as the EngagementDistance dimension is perturbed.

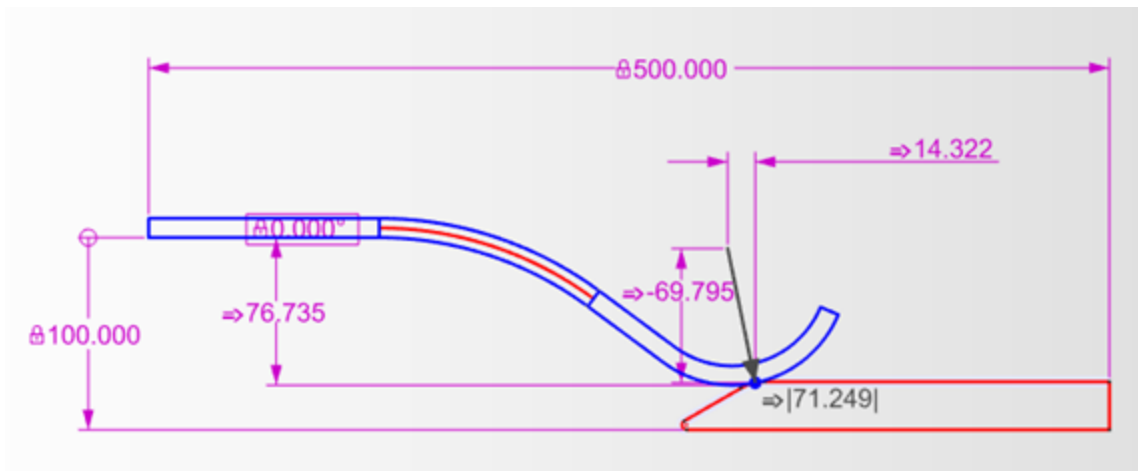

8. Use the Coefficient of Friction tool to add a friction vector to the reaction force. The friction vector should be pointing to the right. If not, select the vector in the Sketch view, and then use the "Switch force endpoints" toggle in the Properties Explorer to change its direction.

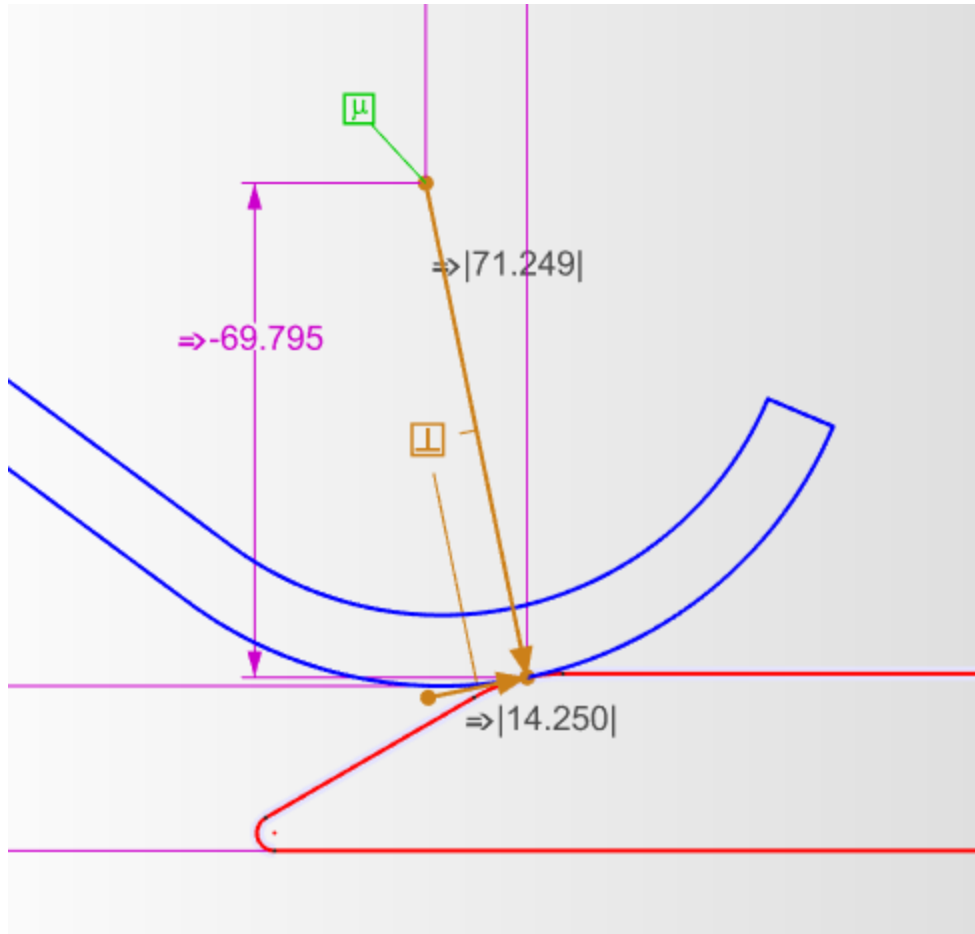

9. Select the coefficient of friction variable (VecFrCoefDim1) in the parameter table, and change its value to 0.15 with a Symmetric tolerance of  $\pm 0.05$ .

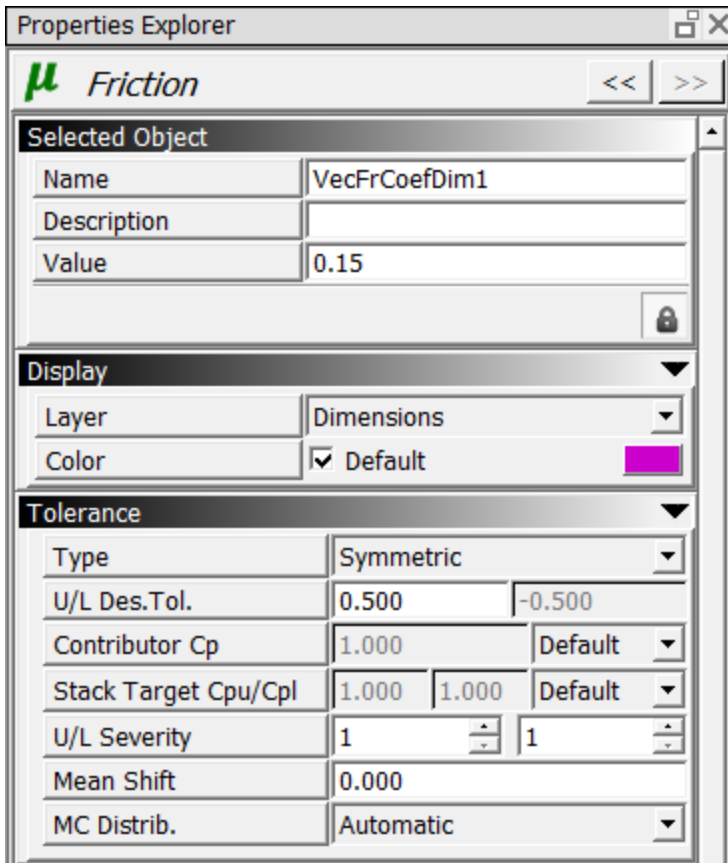

Your model should now appear similarly to the illustration below.

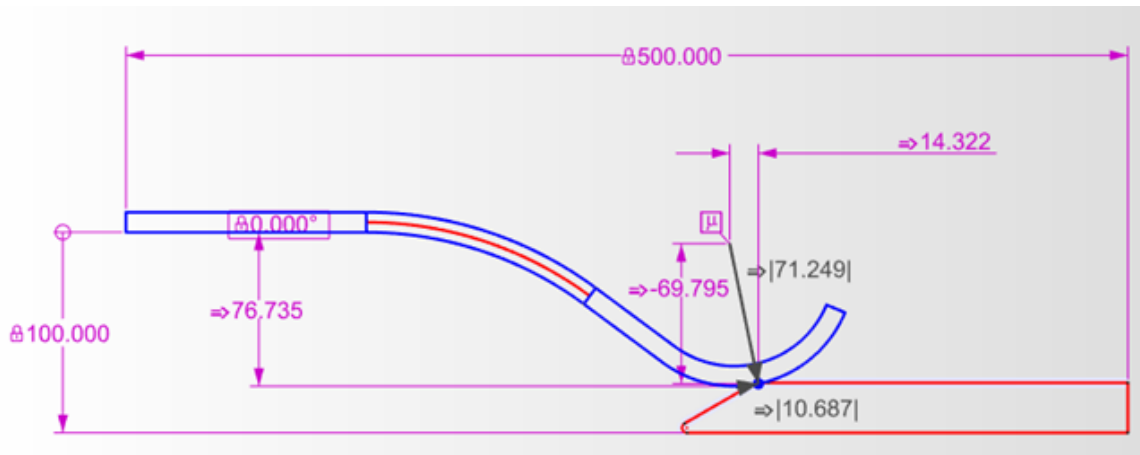

- To complete the free-body diagram, we need to create two more forces: the horizontal insertion force necessary to push the Lifter to the left, and the vertical reaction force that supports the bottom of the Lifter.

Draw these two force vectors, using Point At Midpoint constraints to attach them to the base and right side of the Lifter. (*Hint: Do not select the line objects when drawing the forces to avoid creating Point On Object constraints. If Point On Object constraints are created, deleted them and replace them with Point At Midpoint constraints.*)

Apply perpendicularity constraints as well, and unlock the two force vectors.

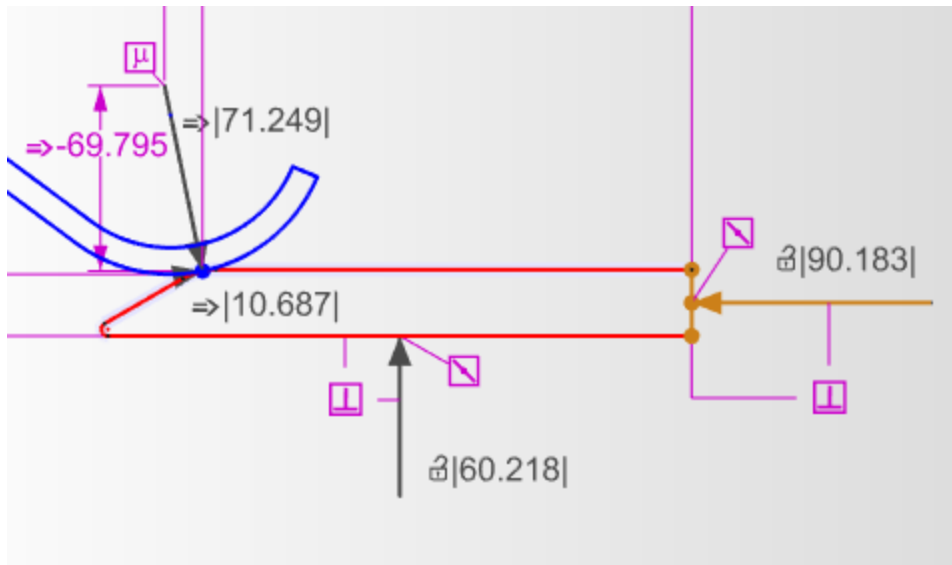

11. Using the Sum Forces to Two Values tool , select all four force vectors, and press **Enter**. (Alternatively, you can use the "Sum Visible to Two Values" option from the Constrain > Force menu options, which will sum all the forces without needing to select them.) Now, all the force vectors should be derived.

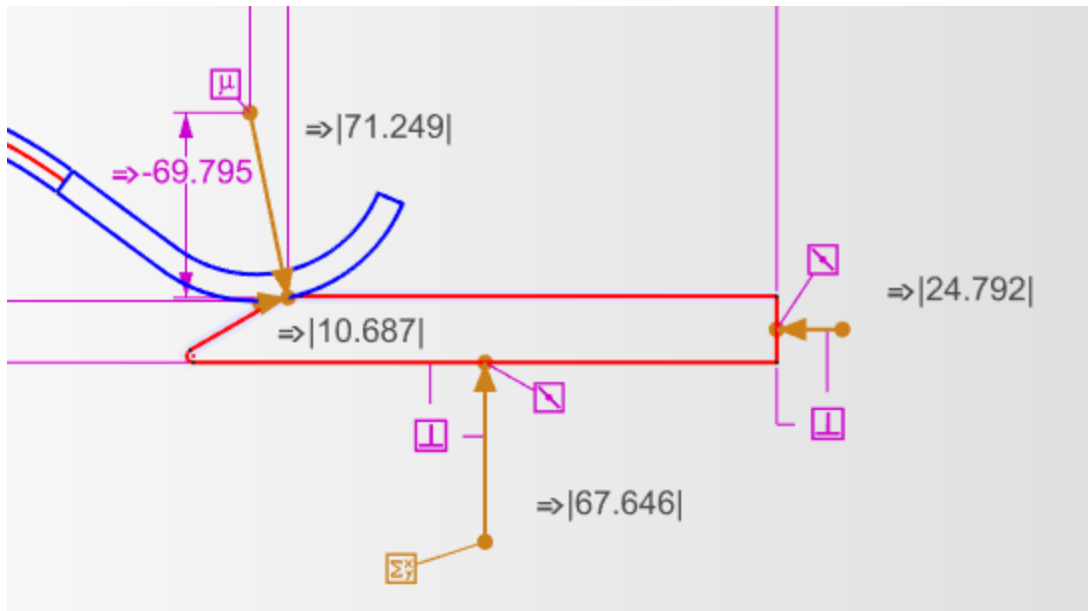

12. In the parameter table, select the horizontal force parameter (the ForValDim parameter with the value 24.792) and change its name to "InsertionForce."
13. Select the EngagementDistance dimension and step its value from 500 to 545.
14. Select both the EngagementDistance dimension and the value of the InsertionForce vector, and initiate a Tolerance-In-Motion (TIM) study (Analysis > Start Tolerance-In-Motion Study...) using the default options.

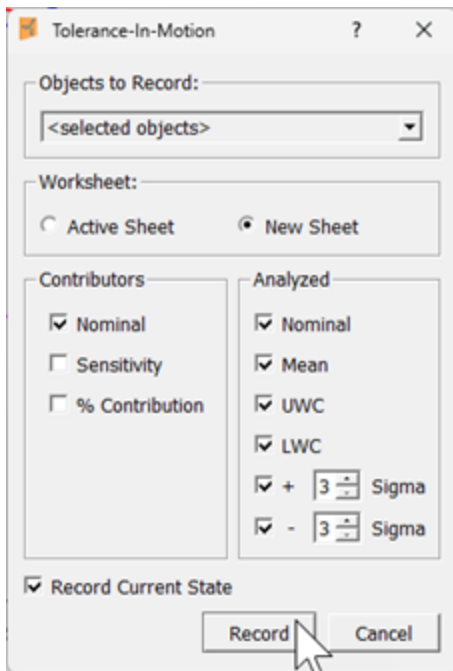

15. Select the EngagementDistance dimension, and step it to a final value of 480, using a step size of 1.

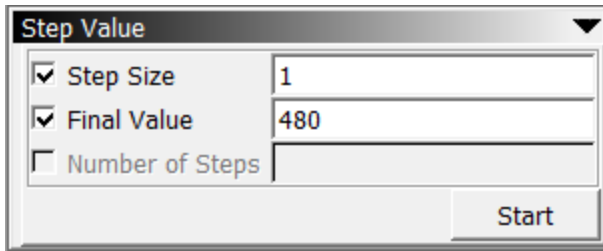

From the message that displays upon completion of stepping, choose **Yes** to pause the TIM recording. (You can stop the TIM recording at any time using Analysis > Stop Current Tolerance-In-Motion Study.)

16. In the spreadsheet, select all of the columns of data, and create a line graph using the Insert Scatter (X Y) option under the INSERT tab.

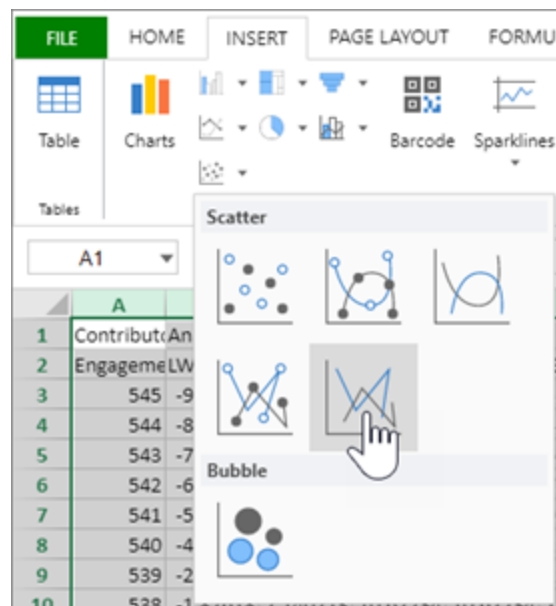
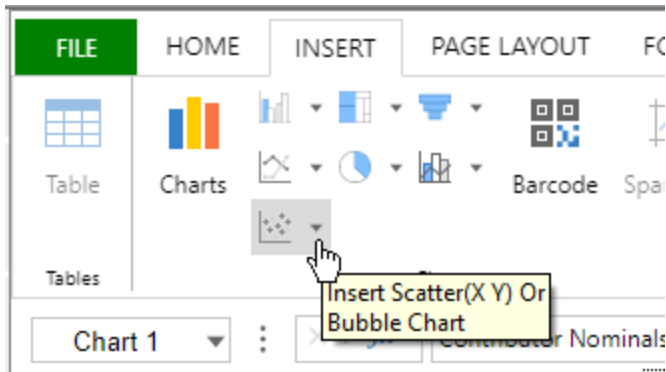

The chart is inserted into the spreadsheet. Note that the data is plotted backwards from the order in which it was recorded, because the EngagementDistance dimension was decreasing.

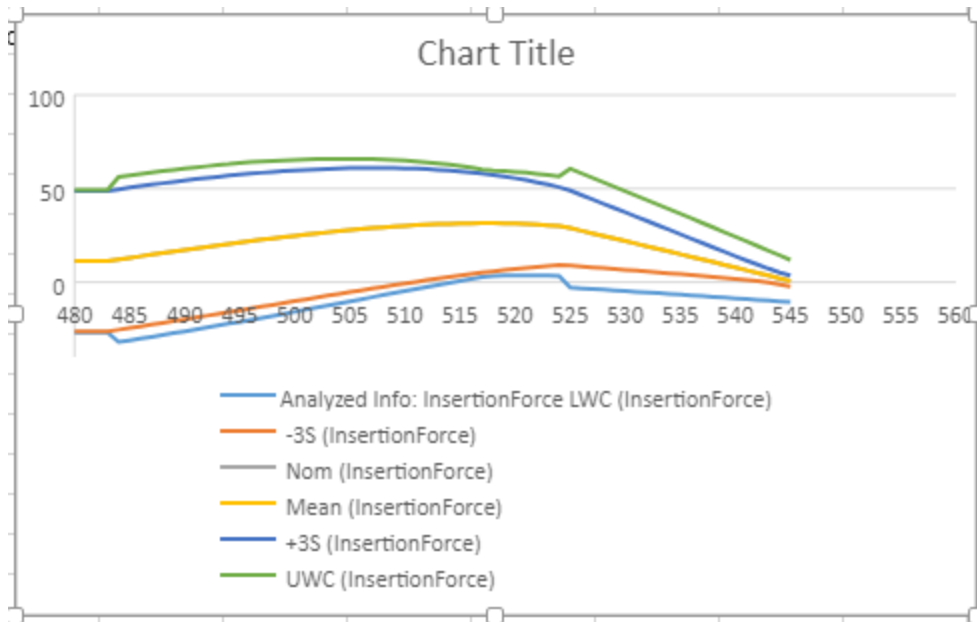

17. Double-click on the x-axis values in the chart to open the Format Axis panel. Click on the third button under Axis Options, which looks like a bar graph.

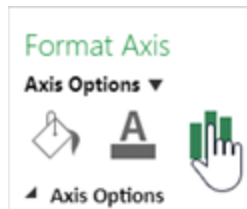

18. Scroll down if needed to find the "Values in reverse order" option and toggle it on.

**Format Axis**

**Axis Options** ▼



▲ **Axis Options**

**Bounds**

Maximum  Auto

Minimum  Auto

**Units**

Units Major  Auto

Units Minor  Auto

**Horizontal axis crosses**

Automatic

At category number

At maximum category

At minimum category

**Display Units**  ▼

Show display units label on chart

Logarithmic scale  ▲▼

Values in reverse order

Tick Marks

19. Now the graph shows how the InsertionForce changes as the Lifter engages the Leaf Spring.

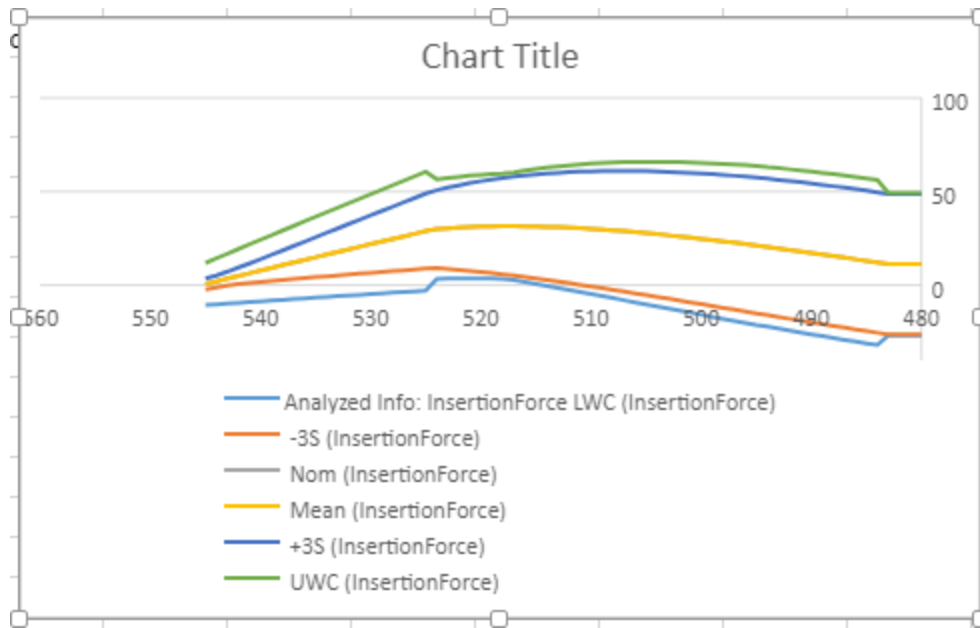

**(Note:** The discontinuities seen in the Worst Case data occur as the point of tangency transitions onto and then off of the radius at the top of the Lifter, which occurs when the reaction force and friction vectors change directions.)

Congratulations! You have completed the bonus exercise of the Deflections Tutorial.